

# The 7000 Series Bus Converter

User's Manual

---

**For the 7520, 7520A, 7520R, 7520AR, 7510, 7510A,  
ISA-7520R, PCI-7520AR, PCISA-7520R and 7561**

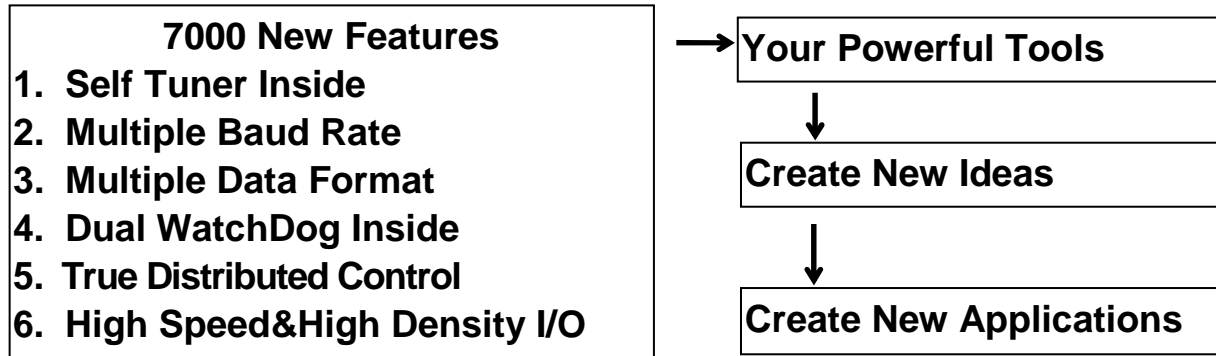

## Warranty

All products manufactured by ICP DAS are under warranty regarding defective materials for a period of one year from the date of delivery to the original purchaser.

## Warning

ICP DAS assumes no liability for damages resulting from the use of this product. ICP DAS reserves the right to change this manual at any time without notice. The information furnished by ICP DAS is believed to be accurate and reliable. However, no responsibility is assumed by ICP DAS for its use, nor for any infringements of patents or other rights of third parties resulting from its use.

## Copyright

Copyright 1997 by ICP DAS. All rights are reserved.

## Trademark

The names used for identification only may be registered trademarks of their respective companies.

# Table of Contents

1. Introduction .....	3
1.1    The 7000 series overview .....	3
1.2    Related Documentation for the 7000 Series .....	4
1.3    Common Features of the 7000 Series .....	5
1.4    The 7000 Series System Network Configuration .....	6
1.5    7000 Dimension .....	10
2. I-7520/A/R/AR, ISA-7520R, PCI-7520AR, PCISA-7520R .....	12
2.1    7520/R Pin Assignment and Specifications .....	12
Block Diagram .....	17
Basic Wire Connection .....	19
2.2    How to Select 7520/7520R .....	20
3. I-7561 .....	24
3.1    Pin Assignment and Specifications .....	24
3.2    The I-7561 System Network Configuration .....	25
3.3    Block Diagram .....	25
3.4    7561 Driver Installation .....	26
3.4.1.  Installation under Win2000/XP .....	26
3.4.2  Installation under Win98/ME .....	33
4. 7510/7510A .....	38
4.1    Pin Assignment and Specifications .....	38
4.2    Block Diagram .....	39
4.3    Basic Wire Connections .....	40
5. 7000 RS-485 Networking .....	41
5.1    Standard/Isolation Configuration .....	41
5.2    PLC Networking Applications .....	45
5.3    PC Networking Applications .....	46
5.4    RS-232 Devices Network .....	47
6. Quick Starting the 7000 Series .....	48
6.1    Find Status of Unknown Module .....	48
6.2    Changing Module Address .....	50
6.3    Changing Baud Rate .....	51
6.4    Checksum Enable/Disable .....	53
6.5    QBASIC Demo Program .....	55

---

# 1. Introduction

The 7000 series is a family of remote controllable data acquisition modules. They provide A/D, D/A, DI/O, Timer/Counter, MMI and other functions. These modules can be controlled remotely by a set of commands.

## 1.1 The 7000 series overview

The 7000 series can be divided into several groups based on their function as follows:

group 1 : bus converter modules, support bus converter & repeater  
7520/7520R/ISA-7520R/PCISA-7520R : RS-232 to RS-485 converter,  
3000V isolation.

7520A : RS-232 to RS485 and RS-422 converter, 3000V isolation.

7520AR/PCI-7520AR: RS-232 to RS485 and RS-422 converter, 3000V isolation.

7561: USB to RS-232/422/485 converter, 3000V isolation.

7510 : RS-485 to RS-485 repeater, 3000V isolation

7510A : RS-485 and RS-422 repeater, 3000V isolation

group 2 : DIO modules, support TTL, isolated DIO, relay & O. C. output

7050 : TTL IO, 7\*In, 8\*Out

7052 : isolated DI, 8\*In

7053 : Non-isolated DI, 16\*In

7060 : isolated DI & relay output, 4\*In+4\*Relay

7041 : isolated DI, 14\*In

7042 : isolated O. C. DO, 13\*Out

7043 : Nonisolated O.C. 16 channels digital output.

7044 : high driver O.C. output I + isolated DI, 4\*In+8\*Out

7063 : isolated DI \*8 & 3 form A power relay.

7065 : isolated DI \*4 & 5 form A power relay.

7066 : 7 form A Photo Mos Relays

7067 : Relay output, 7\*Relay

group 3 : DA module, support voltage/current output.

7021 : 1 channel analog output.

7022 : 2 channel analog output.

7024 : 4 channel analog output.

group 4 : AD modules, support voltage/current/thermocouple/RTD measurement

7011/7011D/7011P : single-channel thermocouple measurement

7012/7012D/7012F : single-channel large signal measurement  
 7013/7013D : 1 channel RTD measurement  
 7033/7033D : 3 channels RTD measurement  
 7014D : Analog/Transmitter input with LEDs display  
 7016/7016D/7016P : Strain Gauge input with LEDs display  
 7017/7018F : Input Range and multi-channel same as 7012.  
 7018 : Thermocouple input, multi-channel 7011  
 group 5 : Timer/Counter modules : 7080, 7080D  
 group 6 : Man Machine Interface : MMICON=240\*64 LCD+4\*4  
 KBDs+8\*function\_key  
 group 7 : Power relay Modules :  
     RM104/108/116 : 4/8/16 channels of form-C, SPST, 400V AC, 16A  
     RM204/208/216 : 4/8/16 channels of form-C, SPDT, 400V AC, 5A  
 group 8 : Embedded Processor module  
     7188, 7188XA, 7188XB, 7188XC, 7188EX, 7188EA  
 group 9 : wireless modem module : SST-288  
 group 10 : Power supply module  
     ACE-540A : 24V/2A power supply  
     DIN-540A : ACE-540A with DIN-RAIL mount  
     PWR-24/220V : 220V AC input, 24V/0.1A output power adapter  
     PWR-24/110V : 110V AC input, 24V/0.1A output power adapter

---

## 1.2 Related Documentation for the 7000 Series

- NAP7000S User Manual : for software NAP7000S, utility program source
- NAP7000P User Manual : for software NAP7000P, DLL driver for 7000
- NAP7000D User Manual : for software NAP7000D, DDE driver for 7000
- NAP7000L User Manual : for software NAP7000O, OLE driver for 7000
- 7000 Bus Converter User Manual :  
     For 7510/7520/7520A/7520R/7561/7510A/7520AR/ISA-7520A/  
     PCI-7520AR/PCISA-7520R
- 7000 DIO User Manual : for 7050/7052/7053/7060/7041/7042/7044/7067
- 7000 A/D Group1 User Manual : for  
     7017/7018/7013/7013D/7033/7033D
- 7000 A/D Group2 User Manual : for 7011/7011D/7012/7012D/7014D
- 7000 D/A User Manual : for 7021, 7022, 7024.
- 7000 Timer/Counter User Manual : for 7080D
- 7000 Embedded Controller User Manual : for 7188
- MMICON Hardware Manual : for MMICON
- MMIDOS User Manual : for MMICON software
- Application Note : EM001 → for MMICON evaluation

---

## 1.3 Common Features of the 7000 Series

### Isolation voltage : 3000 Vdc

#### Communication :

- Asynchronous half-duplex 2-wire RS-485 network
- Max. distance without repeater=4000 feet (1.2Km)
- **Speed=1200,2400,4800,9600,19200,38400,57600,115200**
- **Connecting 256 modules in one RS-485 bus without repeater**
- Multiple baud rate and multiple data format can share the same RS-485 bus(7520/7510)
- Different baud rate and the same module address can share the same RS-485 bus
- **Connecting 256\*8=2048 modules max. in one RS-485 bus with repeater.**
- 7000 series data format=1 start + 8 data + 1 stop + no parity = 10-bit
- Two extra checksum bytes can be enable/disable
- Built-in transient voltage suppresser and PTC protector
- **Sharing the same RS-485 bus with the RS-485 or RS-232 device which communicates in multiple data format(not 10-bit) and multiple baud rate. (Use 7520 to convert RS-232 to RS-485)**

#### Power :

- +10V ~ +30V DC
- Power reverse protection, Over-voltage brown-out protection

#### System :

- Dual watchdog inside, power-on start value and safe value for host failure
- Operating temperature : -25 to 75°C (14 to 185°F)
- Storage temperature : -25 to 80°C (-13 to 185°F)
- Humidity : 5 to 95%, non-condensing

# 1.4 The 7000 Series System Network Configuration

- Multiple Baud Rate
- Multiple Data Format

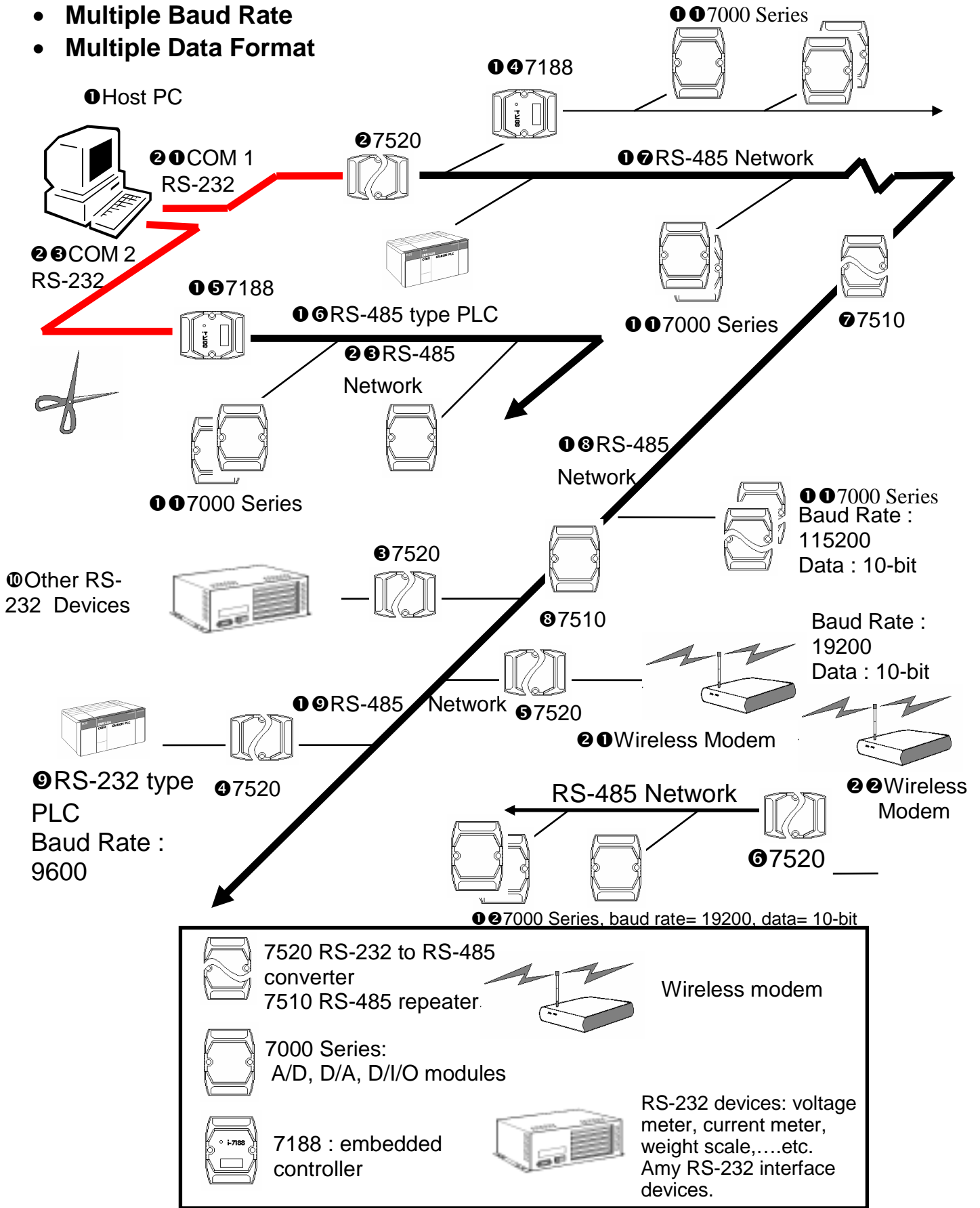

**Fig 1**

**Conventional Two-Wire RS-485 Network:** The conventional two-wire RS-485 network uses a DIP SWITCH selectable converter to convert host RS-232 or USB signal to a two-wire RS-485 signal. The baud rate and data format must be set to a fixed value for the whole network. For example, the user can choose baud rate=9600 and data format=10 bit per character. This limitation is inconvenient for some real world applications. The 7000 series, Adam 4000 series, Nudam 6000 series and DATAFORTH 9B series all use a 10-bit format. Some conventional PLC use 11-bit data format and some weight scale equipment uses 12-bit. If the host-PC has to send command to remote modules, PLC and weight scale equipment, one possibility is to use three independent two-wire RS-485 networks. However, this may increase the system cost and reduced the system reliability.

An other option for the user is to use many modules in the same two-wire RS-485 network for real world applications. All these modules must communicate at the same baud rate in a conventional system. Some of those modules may be very close to the host-PC and will be able to communicate at a high baud rate. Some modules may be far away from the host-PC and will communicate at a low baud rate. Because only one speed is vallid in the RS-485 network, the high speed modules should be forced to communicate at a low speed baud rate. In other words, the performance of the whole system should be decreased.

**The 7000 Series RS-485 Network:** The 7000 RS-485 network is the most powerful and flexible two-wire RS-485 network in the world. It is a multiple baud rate and multiple data format network system. That is to say, all the remote modules mentioned above, PLCs and weight scale equipment share the same RS-485 network. The 7520, RS-232 to RS-485 converter, equips a “**Self Tuner**” inside, therefore it can detect the baud rate and data format automatically and control the direction of the RS-485 network precisely. Therefore the user can connect all this equipment to the same RS-485 network. This method will greatly reduce system cost and increase reliability.

### **Operation Principle (Refer to Fig 1):**

- (1) The ①Host PC sends out commands via the ②①COM1.
- (2) The ②7520 converts this RS-232 signal into ①⑦RS-485 signal.
- (3) All modules connecting to ①⑦RS-485, ①⑧RS-485 and ①⑨RS-485 network will receive this command at the same time. Then, all modules will begin extracting the destination address field and compare it to its local module address.
- (4) The module with matched addresses will continue to execute this host command while other modules will bypass it.
- (5) After executing the host command, the destination module will send the result back into RS-485 network. The ①Host PC will interpret this result and take action.

**Isolated Repeater:** The ⑦7510 & ⑧7510 are used to extend the ①⑦RS-485 to ①⑧RS-485 & ①⑨RS-485 for the following three uses : (1) the RS-485 path is over 1.2Km or 4000 ft (2) connecting over 256 modules in one RS-485 segment (3) break a long RS-485 path into several short & isolated RS-485 paths for safety considerations.

**Multiple Baud Rate :** The modules patched into the 7000 two-wire RS-485 network can communicate to ①Host PC at different baud rate. For example, the max. speed of ②①Wireless Modem & ②②Wireless Modem is 19200 BPS, but all 7000 series module can operate under 115200 BPS. Some conventional PLC can only communicate at 9600 max. The 7520 can auto switch the baud rate from 300 BPS to 115200 BPS. Therefore the user can connect all their device into the same RS-485 network. The ①Host PC will send out the different baud rate command and only the corresponding destination module will recognize this command and echo its result. All the other modules will recognize this command as a invalid command and bypass it.

**Multiple Data Format:** The RS-232 is a serial signal and must be transmitted in START-bit+DATA-bit+PARITY-bit+STOP-bit. The format of ICP CON is “1 START-bit+8 DATA-bit + no PARITY-bit + 1 STOP-bit”, a total of 10 bits. However, the conventional PLC uses “1 START+7 DATA+1 PARITY+2 STOP”, a total of 11 bits. The ①Host PC can send and receive any data format command. The devices connecting in the 7000 two-wire RS-485 network can communicate to ①Host PC with different data formats. This feature allows the user to use one two-wire RS-485 network to connect remote modules, PLCs, RS-232, devices and instruments in the most reliable and cost efficient way.

**Dual WatchDog Inside:** All 7000 series modules equip hardware module watchdog and software host watchdog. The 7000 series is designed for industry applications, therefore they can work without problem in harsh environments. There is a lot of network noise or transient energy in such an environments. The modules may shut down if these noises are too large. However, The built-in hardware module watchdog will reset the module if it is down due to an overly large signal. Sometimes even the host-PC may be down for hardware or software reasons. The software host watchdog can monitor the status of host-PC. If the host-PC is down, all the output of 7000 modules will go to their predefined safe states for safety protection.

If the RS-485 network is open, all of the host commands aren't able to send to remote modules. This is very dangerous in real world applications. The 7000 output module will force their output to go to their predefined safe state for safety consideration if the host watchdog is enabled. This dual watchdog feature will greatly increase system reliability.

**True Distributed Control:** The ①④7188 and ①⑤7188 are equipped with a 80188, ram, flash eeprom and can download user programs. Therefore they can handle control details without ①Host PC. This is a very important feature of the 7000 series. All the 7000 modules work in “SLAVE” state. They are all waiting for commands from which to respond. They aren't able to take action to ①Host PC in a given condition. Therefore the user cannot handle critical timing and emergency events by using the 7000 series modules. The 7188 is the best choice for this application. The ①⑤ 7188 can work in stand alone mode after the control program is downloaded.

# 1.5 7000 Dimension

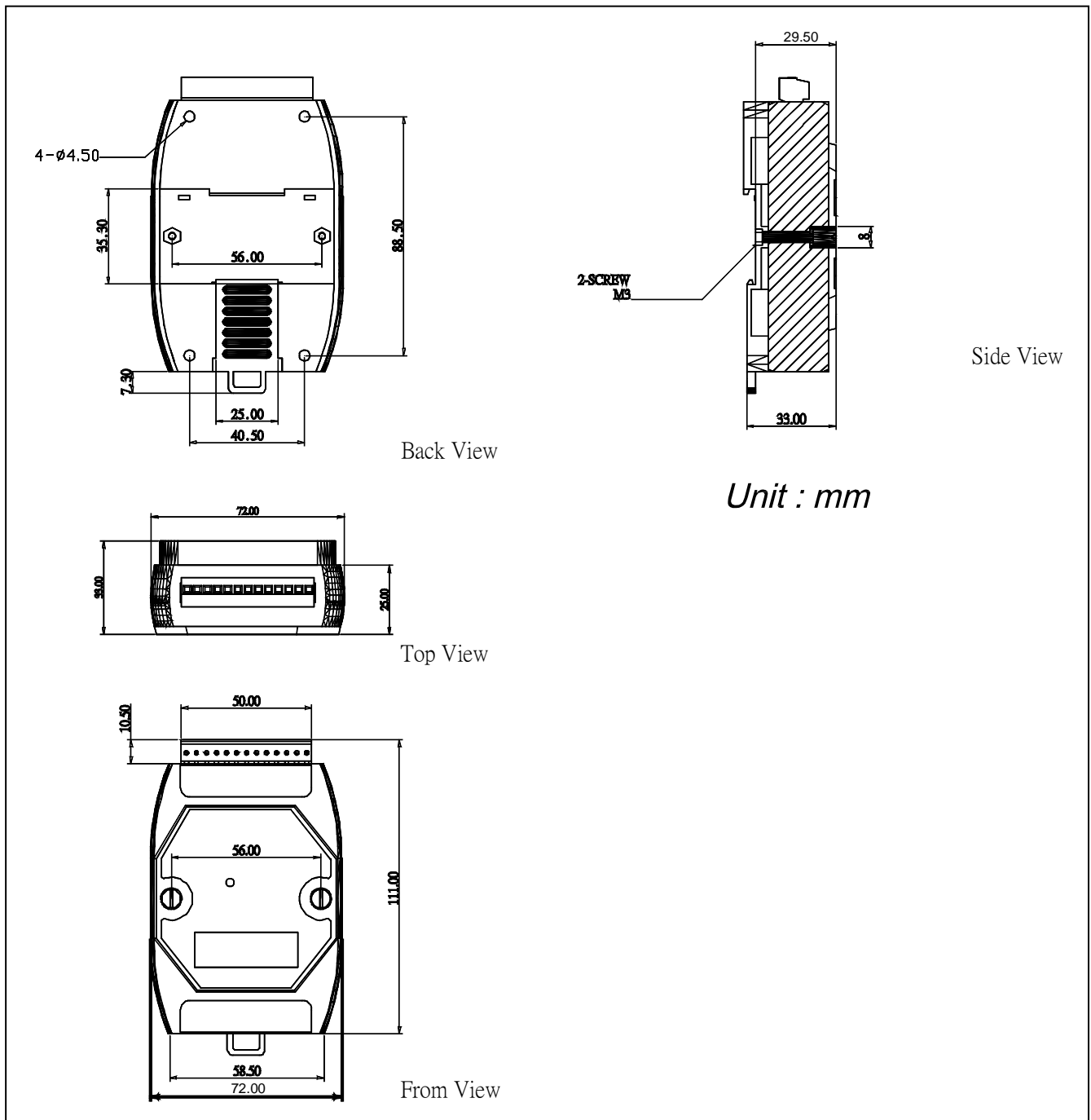
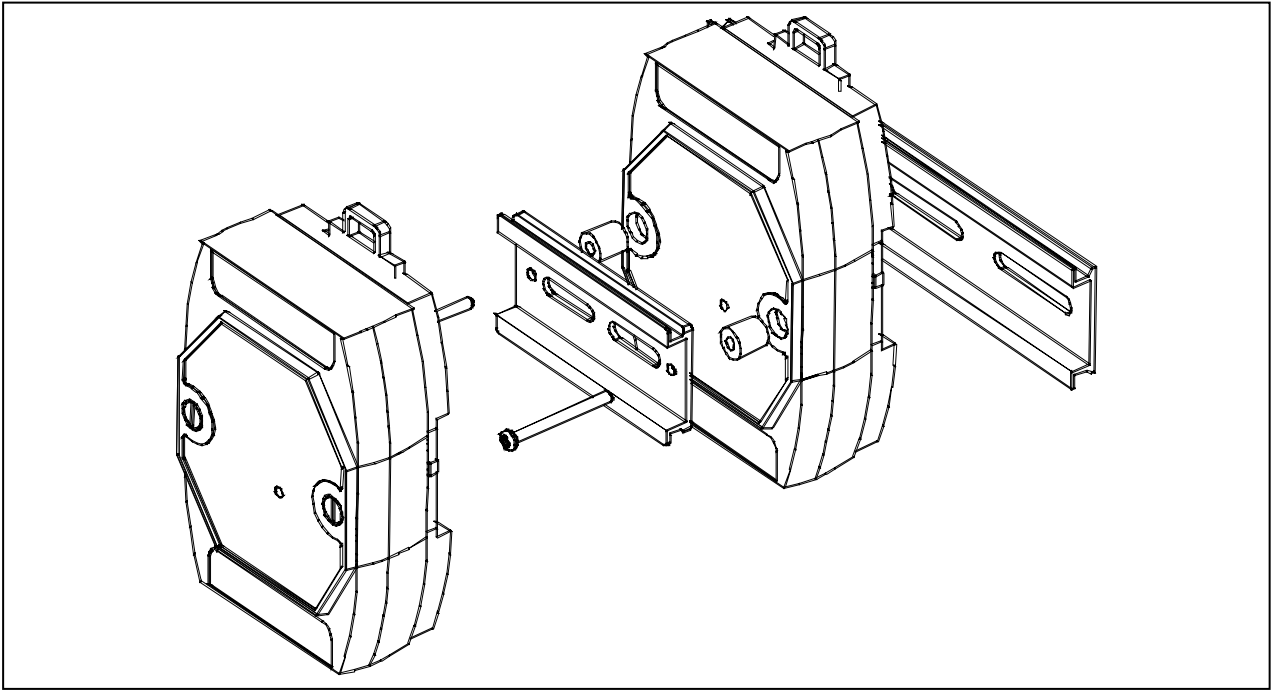
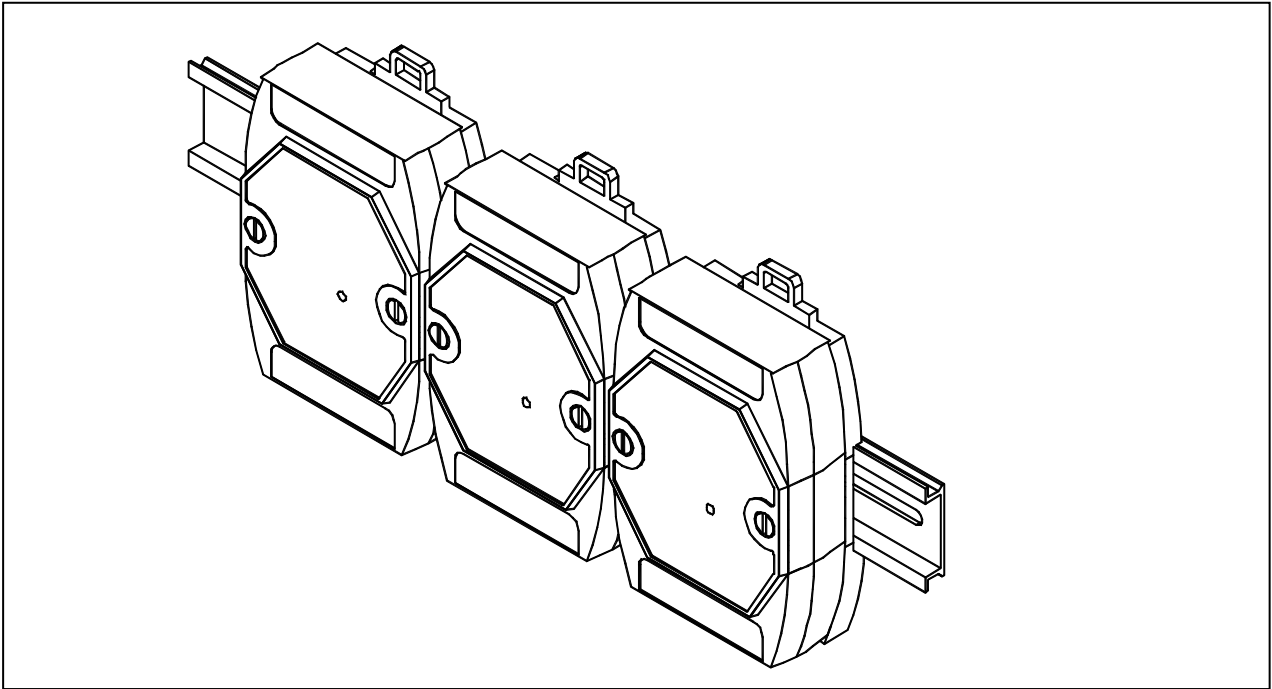

Fig 2



**Stack Mounting**

**Fig 3**



**Din – Rail Mounting**

**Fig 4**

## 2. I-7520/A/R/AR, ISA-7520R, PCI-7520AR, PCISA-7520R

### 2.1 7520/R Pin Assignment and Specifications

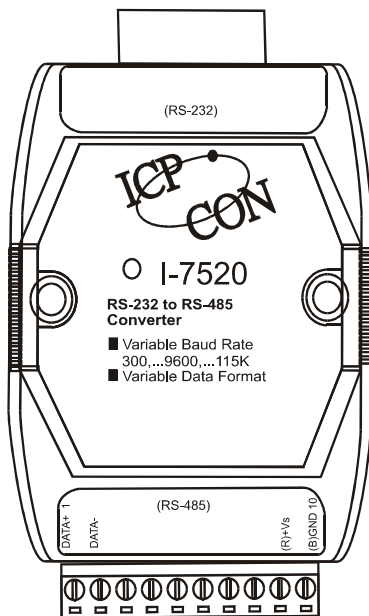

Fig 5

#### 7520 : RS-232 to RS-485 Converter

- Protocol : two-wire RS-485, (D+,D-), protocol
- Connector : plug-in screw terminal block
- Speed : “Self Tuner” inside, auto switching baud rate, from 300 to 115200 BPS
- 256 modules max in one RS-485 network without repeater
- 2048 modules max in one RS-485 network with repeater
- Isolation voltage : 3000V
- **Isolation site : RS-232**
- Repeater request : 4,000 feet or over 256 modules
- Power requirements: +10V to +30VDC Power consumption : 2.2W(Max)

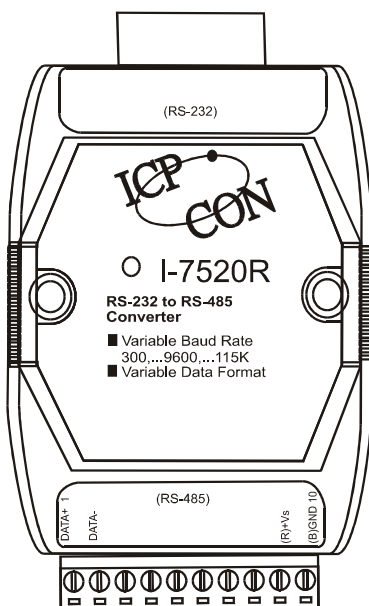

Fig 6

#### 7520R : RS-232 to RS-485 Converter

- Protocol : two-wire RS-485, (D+,D-), protocol
- Connector : plug-in screw terminal block
- Speed : “Self Tuner” inside, auto switching baud rate, from 300 to 115200 BPS
- 256 modules max in one RS-485 network without repeater
- 2048 modules max in one RS-485 network with repeater
- Isolation voltage : 3000V
- **Isolation site : RS-485**
- Repeater request : 4,000 feet or over 256 modules
- Power requirements: +10V to +30VDC Power consumption : 2.2W(Max)

# 7520A/AR Pin Assignment and Specifications

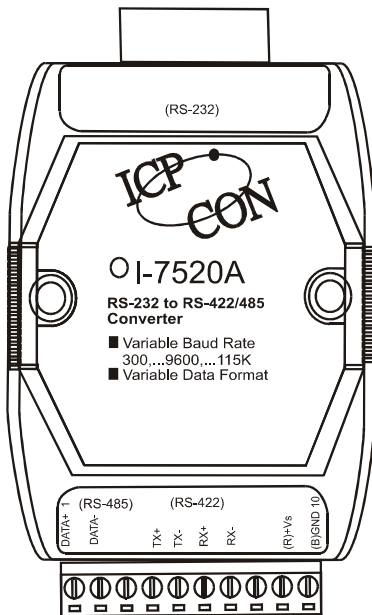

Fig 7

## 7520A : RS-232 to RS-422/485 Converter

- Protocol : RS-422/485
- Connector : plug-in screw terminal block
- Speed : “Self Tuner” inside, auto switching baud rate, from 300 to 115200 BPS
- 256 modules max in one RS-485 network without repeater
- 2048 modules max in one RS-485 network with repeater
- Isolation voltage : 3000V
- **Isolation site : RS-232**
- Repeater request : 4,000 feet or over 256 modules
- Power requirements: +10V to +30VDC Power consumption : 2.2W(Max)

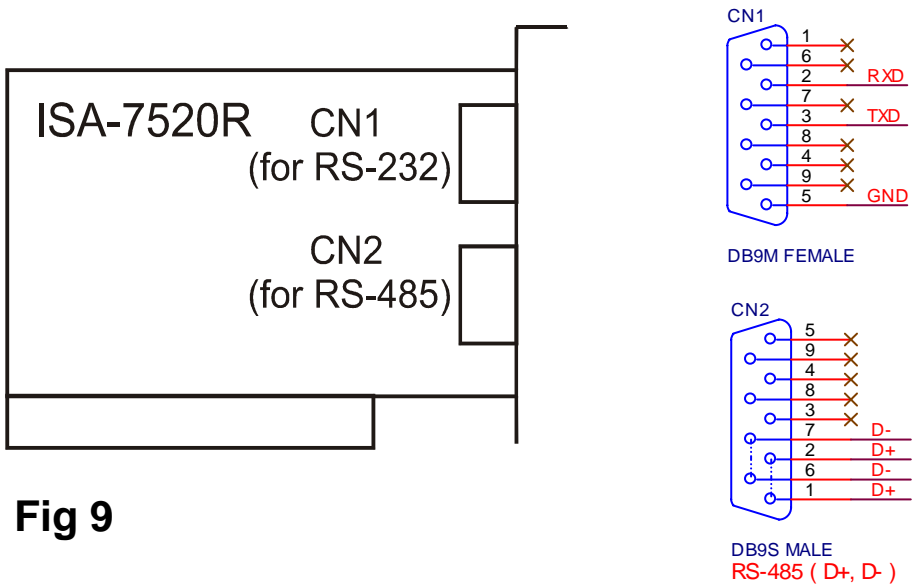

Fig 8

## 7520AR : RS-232 to RS-422/485 Converter

- Protocol : RS-422/485
- Connector : plug-in screw terminal block
- Speed : “Self Tuner” inside, auto switching baud rate, from 300 to 115200 BPS
- 256 modules max in one RS-485 network without repeater
- 2048 modules max in one RS-485 network with repeater
- Isolation voltage : 3000V
- **Isolation site : RS-422/485**
- Repeater request : 4,000 feet or over 256 modules
- Power requirements: +10V to +30VDC Power consumption : 2.2W(Max)

# ISA-7520R Pin Assignment and Specification



**Fig 9**

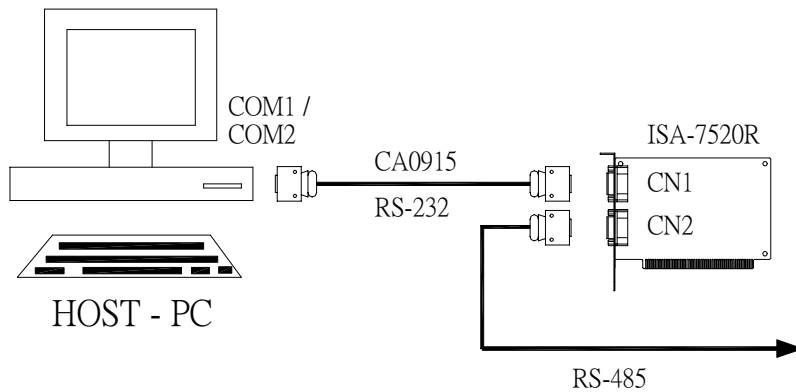

**CON2 : RS-485 DB9 Male Connector**

Terminal	2-wire RS-485
1	DATA+
2	
3	
4	Not Connect
5	
6	DATA-
7	
8	
9	Not Connect

**The ISA-7520R is exactly the same as 7520R except for the ISA interface. It is designed for easy installation.**

# PCI-7520AR Pin Assignment and Specification

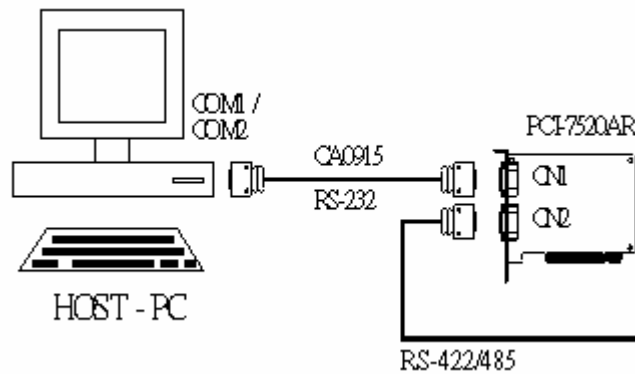
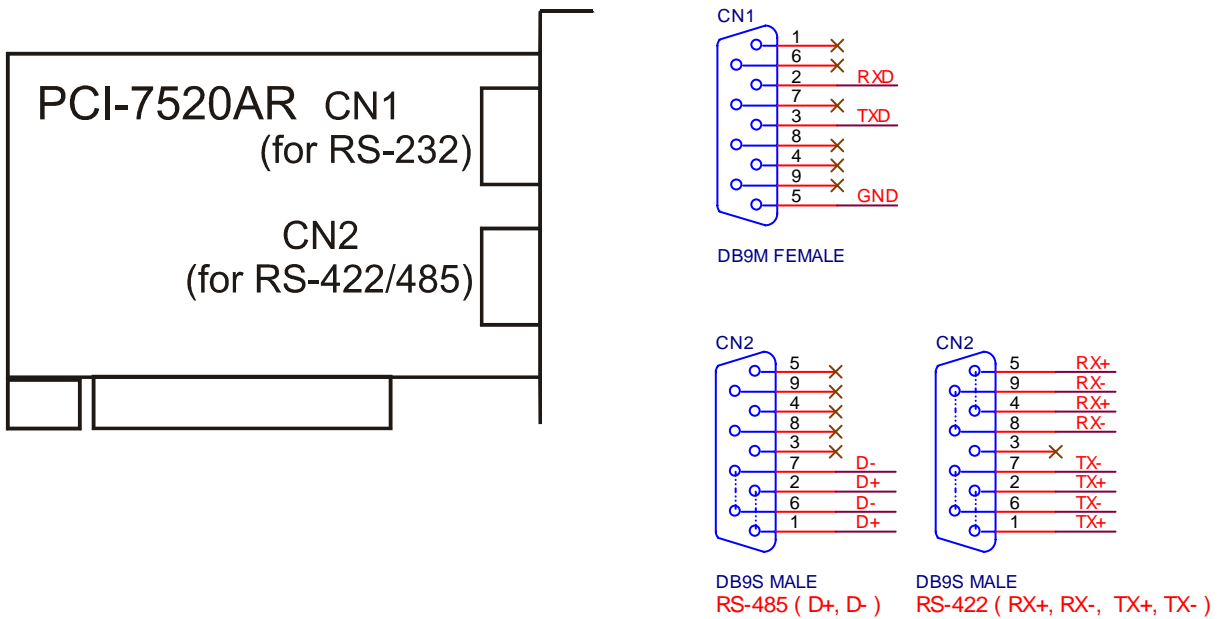

**CON2 : RS-485/422 DB9 Male Connector**

Terminal	2-wire RS-485	4-wire RS-422
1	DATA+	TX+
2		
3	Not Connect	
4	Not Connect	RX+
5		
6	DATA-	TX-
7		
8	Not Connect	RX-
9		

The PCI-7520AR is exactly the same as 7520AR except for the ISA interface. It is designed for easy installation.

# PCISA-7520R Pin Assignment and Specification

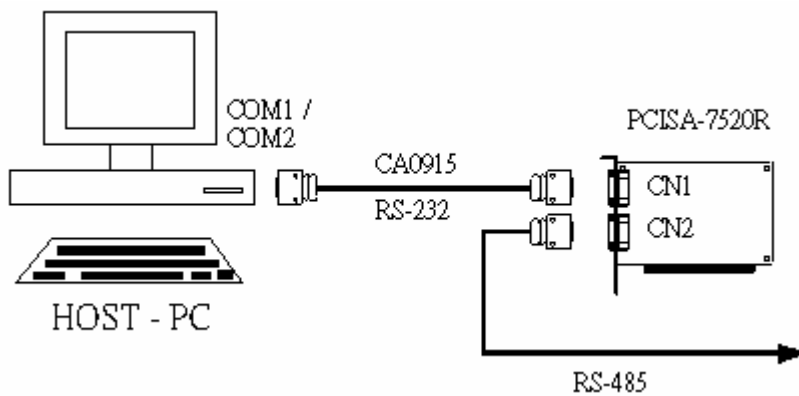
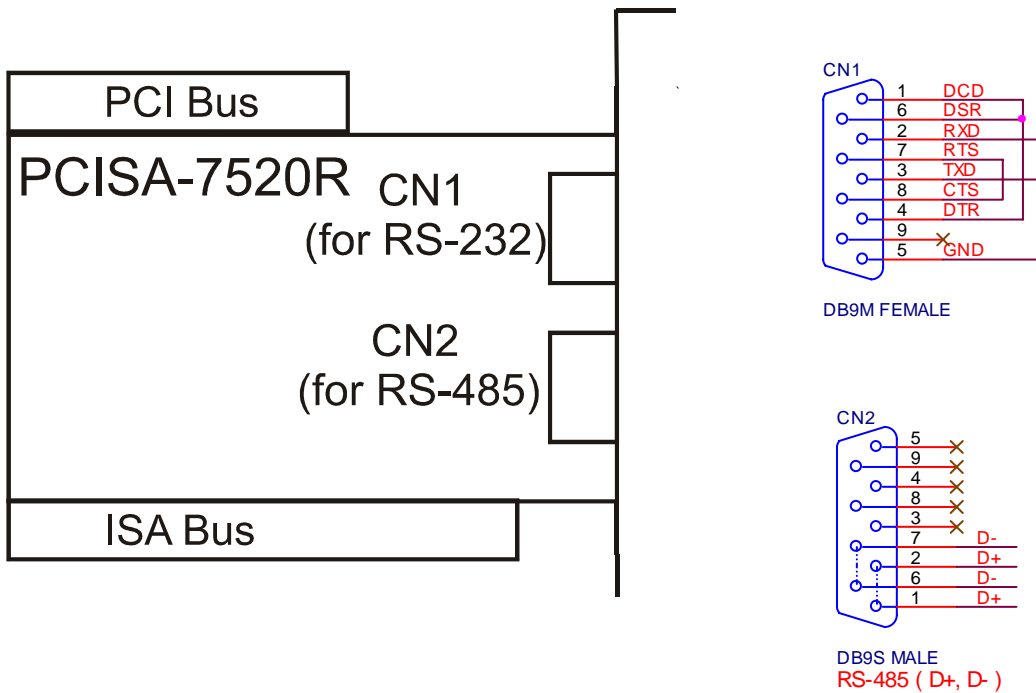

**CON2 : RS-485 DB9 Male Connector**

Terminal	2-wire RS-485
1	DATA+
2	
3	Not Connect
4	
5	
6	DATA-
7	
8	Not Connect
9	

The PCISA-7520R is exactly the same as 7520R except for the ISA interface. It is designed for easy installation.

# Block Diagram

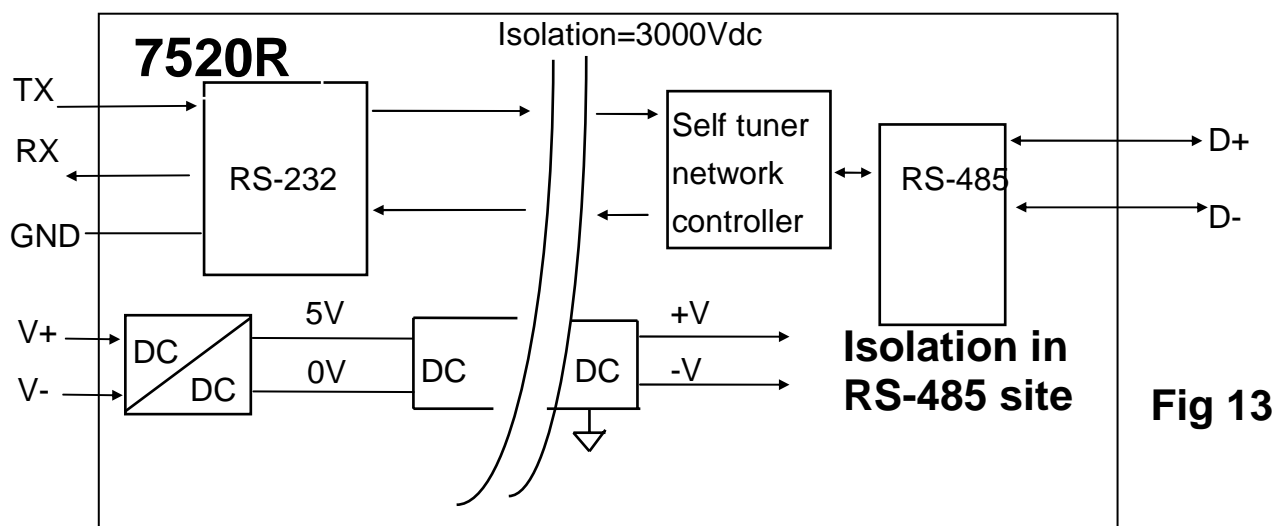
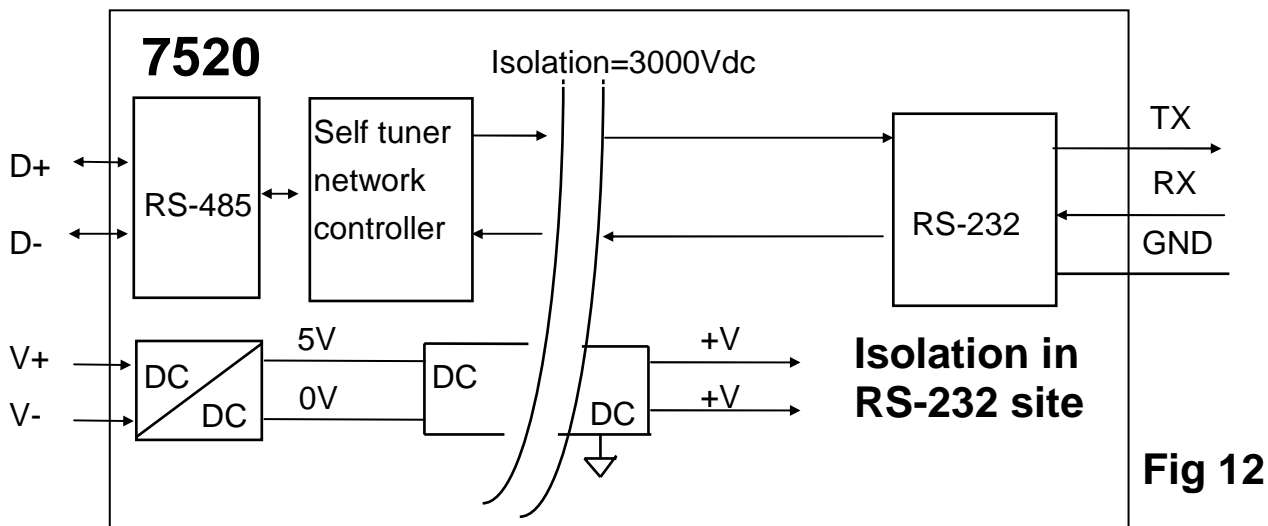

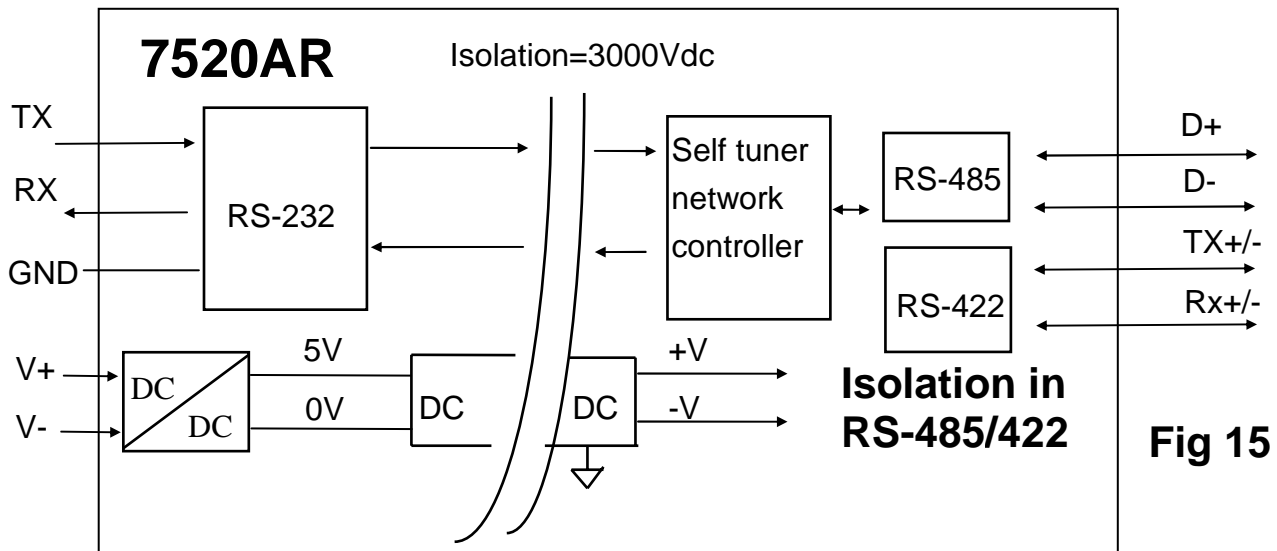
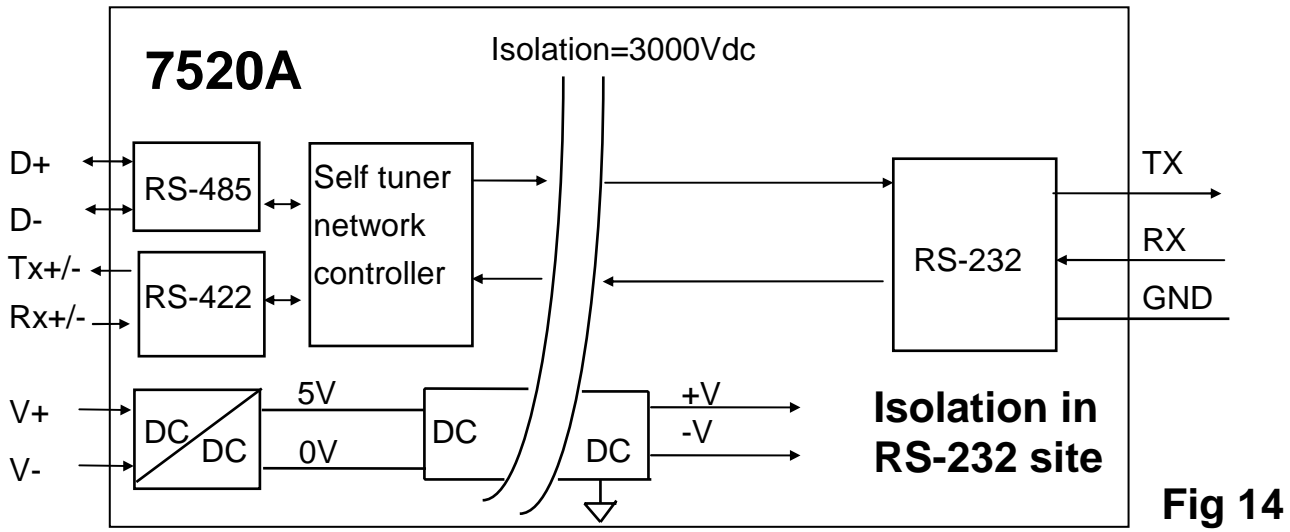

# Basic Wire Connection

## RS 485 wire connection.

GND ↔ Ext. Power GND  
 +VS ↔ Ext. Power 10V-30V  
 Data- ↔ Data-  
 Data+ ↔ Data+

## RS 232 wire connection

host pin2(RXD) ↔ 7520\_pin2  
 host pin3(TXD) ↔ 7520\_pin3  
 host pin5(GND) ↔ 7520\_pin5

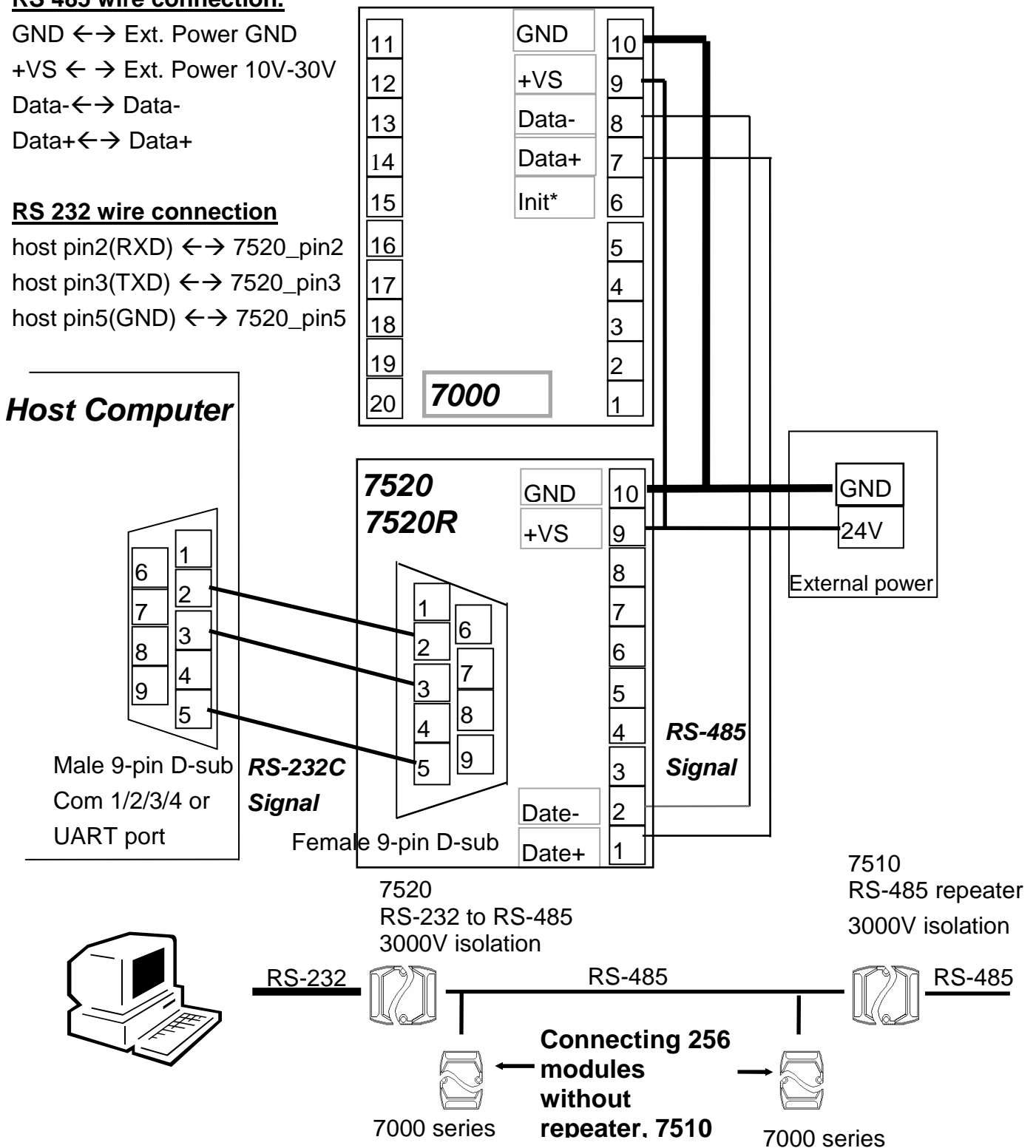
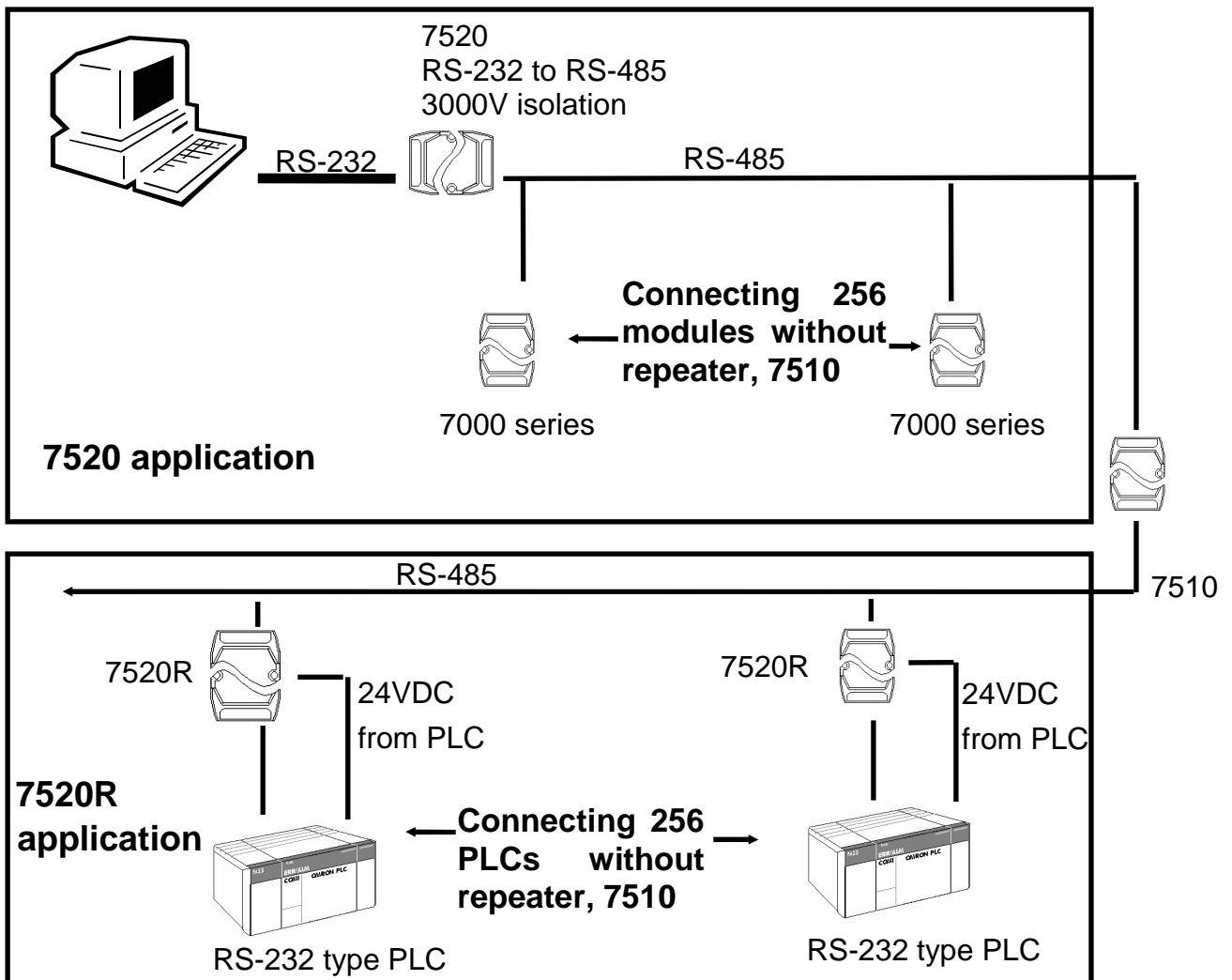

Fig 16

## 2.2 How to Select 7520/7520R

The 7520R is exactly the same as 7520 **except for the isolation site**. The isolation site of the **7520 is located in the RS-232 interface circuit**, but the isolation site of the **7520R is located in the RS-485 interface circuit**. That is to say, the power input and RS-485 interface is common ground for the 7520 but the power input and RS-232 interface is only common ground for the 7520R as follows:

	7520	7520R
RS-485 site	Common ground	Isolation site
Power ground		Common ground
RS-232 site	Isolation site	
Applications	Most applications.	For RS-232 type PLC networking



**Fig 17**

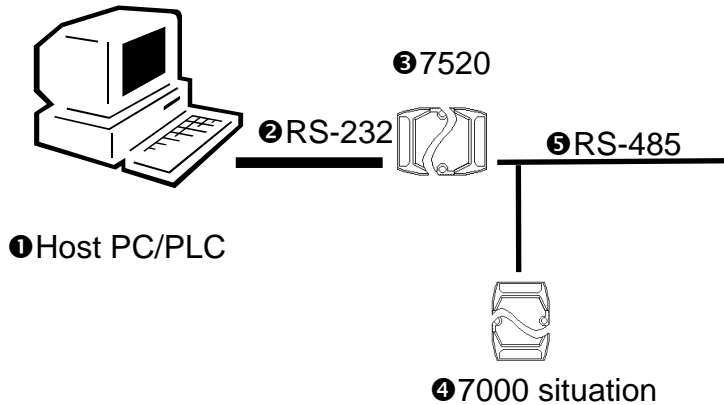

**Fig 18**

Note : the power ground of ④7000 and ⑤RS-485 is **common ground**. This is the same for Adam 4000, Nudam 6000 and DATAFORTH 9B series modules.

In most applications, the ③7520 is used to convert the ②RS-232 signal to ⑤RS-485 network. Normally the ③7520 does not use the same DC power ground as the ①Host PC/PLC, and the isolation site is in the RS-232 section. Therefore the ①Host PC/PLC is isolated from ⑤RS-485 network. That is to say, if there is any high voltage transient on ⑤RS-485 network, the ①Host PC/PLC will be free from damage.

**WARNING!! ERROR CONDITION 1:** if the ③7520 is replaced by ③7520R and the ③7520R uses the same DC power ground with ④7000. In this situation,

- (1) The ①Host PC/PLC is common ground with ②RS-232
- (2) The ②RS-232 is common ground with power ground of ③7520R
- (3) The power ground of ③7520R is common ground with power ground of ④7000
- (4) The power ground of ④7000 is common ground with ⑤RS-485

Therefore the ①Host PC/PLC is common ground with ⑤RS-485 network. That is to say, there is no isolation between ①Host PC/PLC and ⑤RS-485 network. The ①Host PC/PLC may be damaged if there is high voltage transient on ⑤RS-485 network.

**WARNING!! ERROR CONDITION 2:** if the ③7520 uses the same DC power ground with ①Host PC/PLC (for example, ①Host PC/PLC provide non-isolated DC power source to ③7520). In this situation,

- (1) The ①Host PC/PLC is common ground with power ground of ③7520
- (2) The power ground of ③7520 is common ground with ⑤RS-485

Therefore the ①Host PC/PLC is common ground with ⑤RS-485 network. That is to say, there is no isolation between ①Host PC/PLC and ⑤RS-485 network. So the ①Host PC/PLC may be damaged if there is high voltage transient on ⑤RS-485 network.

**OK CONDITION :** If the DC power ground of ③7520 or ③7520R is not common to any module, the ①Host PC/PLC will be isolated from ⑤RS-485 network in all conditions.

The power adapter PWR-24 is designed for single 7000 series modules only. The 24V DC output of the PWR-24 is isolated from its AC input. If the ③7520 or ③7520R is connectd to the PWR-24, this PWR-24 cannot connect to the other module. Normally the ①Host PC/PLC uses a switching power and the DC output of this power supply is also isolated from its AC input. Therefore the DC power ground of ③7520 or ③7520R is isolated from ①Host PC/PLC. Therefore, the ①Host PC/PLC is isolated from ⑤RS-485 network in all condition.

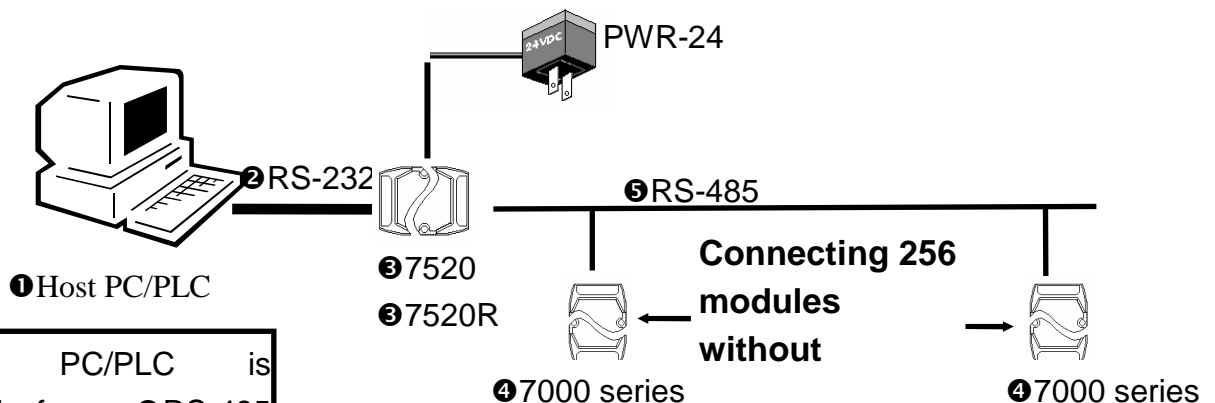

①Host PC/PLC is isolated from ⑤RS-485 network for ③7520 or ③7520R in all condition

**Fig 19**

The 7520R is designed for PLC networking. During normal conditions, the PLC system will have a stable DC-24V power source. The user may use this power source to ⑥7520R(configuration\_A). When using ⑦7520, the user must use another power source, ③PWR-24(configuration B).

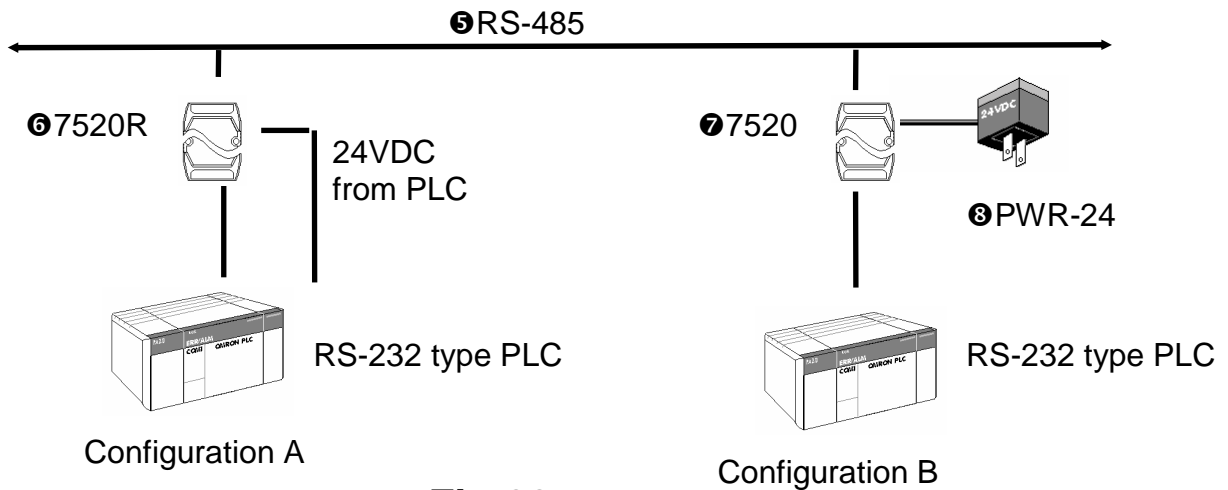

**Fig 20**

The isolation feature is very important in real world applications, therefore the user should pay attention when selecting the correct module. If the wrong module is selected, the isolation will be removed but the module will still function OK. This may cause unexpected damaged by high energy transients on a RS-485 network.

---

## 3. I-7561

### 3.1 Pin Assignment and Specifications

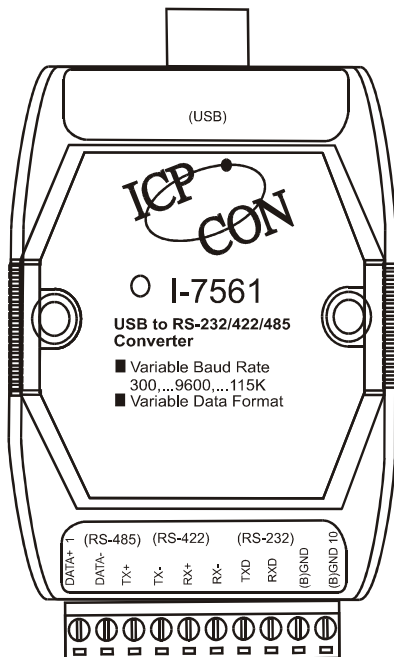

Fig 21

#### Introduction

The **I-7561** is a cost-effective module for transfer serial data over USB. It allows you to connect your serial devices to systems using a USB interface. Connecting the **I-7561** to a PC, you get one or two extra high-speed RS-232/422/485 ports. Like our I-7520A, the I-7561 contains “ Self Tuner “ This chip auto-tunes the baud rate and data format to the RS-485 network. The I-7561 module derives the power from the USB port and doesn't need any power adapter. It also features a high-speed 920K /115.2 Kb/s transmission rate, and supports various O.S. independent RS-232/422/485 Ports.

#### Specifications

- Compatibility: USB 1.1 standard
- Input port : USB
- Output port: 3-wire RS-232, RS-422, RS-485.
- Cable: USB type A connector (Type A to Type B cable provided).
- Isolation voltage: 3000VDC
- “Self Tuner” inside, support multiple Baud Rate and multiple Data Format
- Auto switching baud rate, 300~920K BPS
- 256 modules max. in one RS-422/485 network without repeater
- Isolation voltage: 3000VDC
- Repeater request: 4,000 feet or over 256 modules
- Communication distance:
  - 2.1Km/9600 Bps
  - 2.7Km/4800 Bps
  - 3.6Km/2400 Bps
- Mounting: Din-rail, wall mounting, pinggyback stack.
- Power consumption: 1.5 W max.
- Operatiog temperature: -25°C to +75°C
- Storage temperature: -25°C to +80°C
- Humidity: 5~ 95%
- **Driver Supported:** Windows 98/ME/2000, XP, Linux

### 3.2 The I-7561 System Network Configuration

- Multiple Baud Rate
- Multiple Data Format

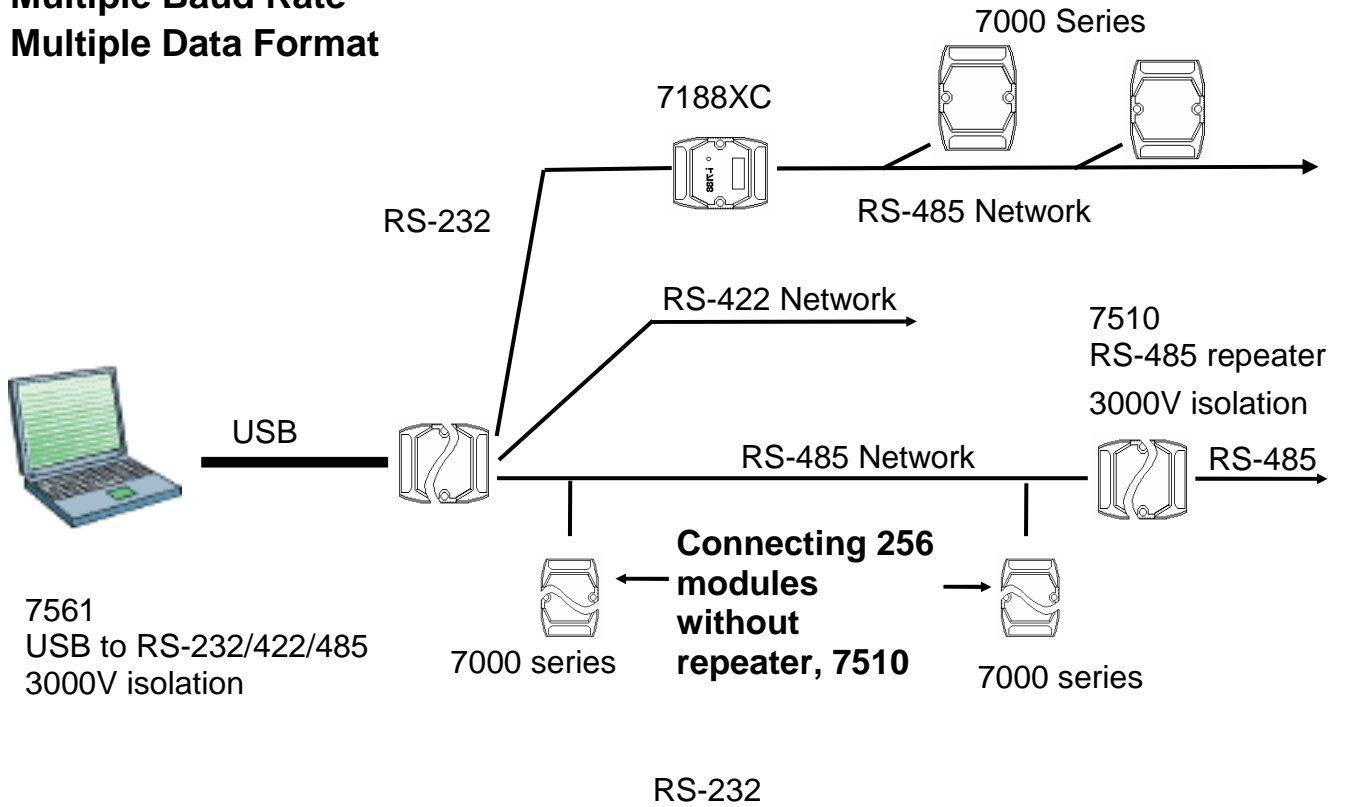

Fig 22

### 3.3 Block Diagram

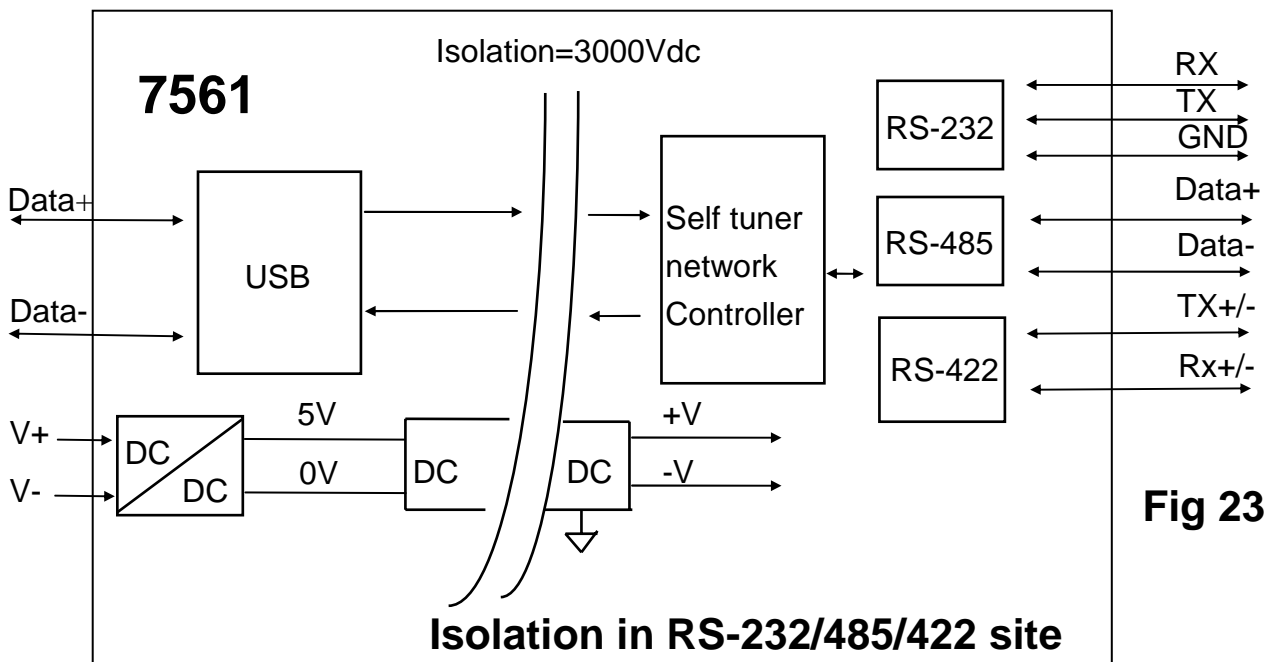

Fig 23

---

## 3.4 7561 Driver Installation

The drivers of the 7561 module include: a USB-RS232 driver and USB COM Port driver. The drivers are supplied for Windows 98/ME/2000/XP (No support for WinNT). Download driver files from

1. Package CD, \Napdos\7000\7561\driver
2. <ftp://ftp.icpdas.com/pub/cd/8000cd/napdos/7000/7561/driver>

### 3.4.1. Installation under Win2000/XP

#### 3.4.1.1 Install USB-RS232 driver

Follow the steps below:

Step 1: Plug the USB cable into the USB HUB port located on the back of your computer (it is shown in the “found New Hardware” windows as below), click “Next” to continue.

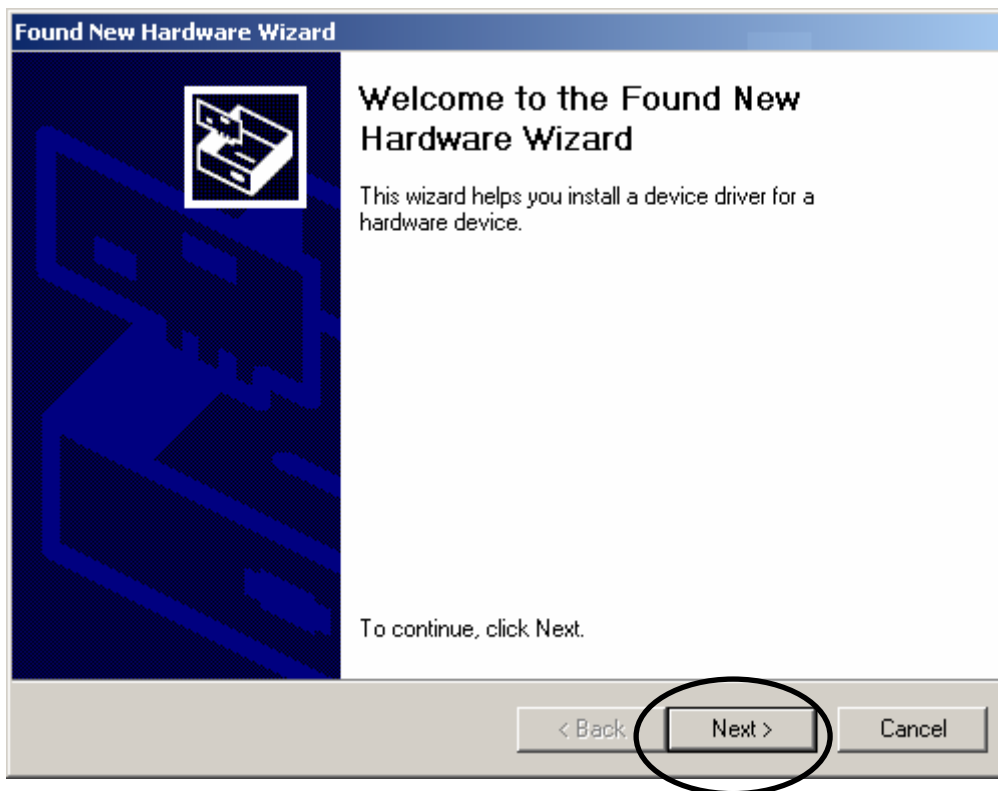

Step2: "Install Hardware Device Drivers" windows is shown, Click "Next" to initiate a search for a suitable driver for your device.

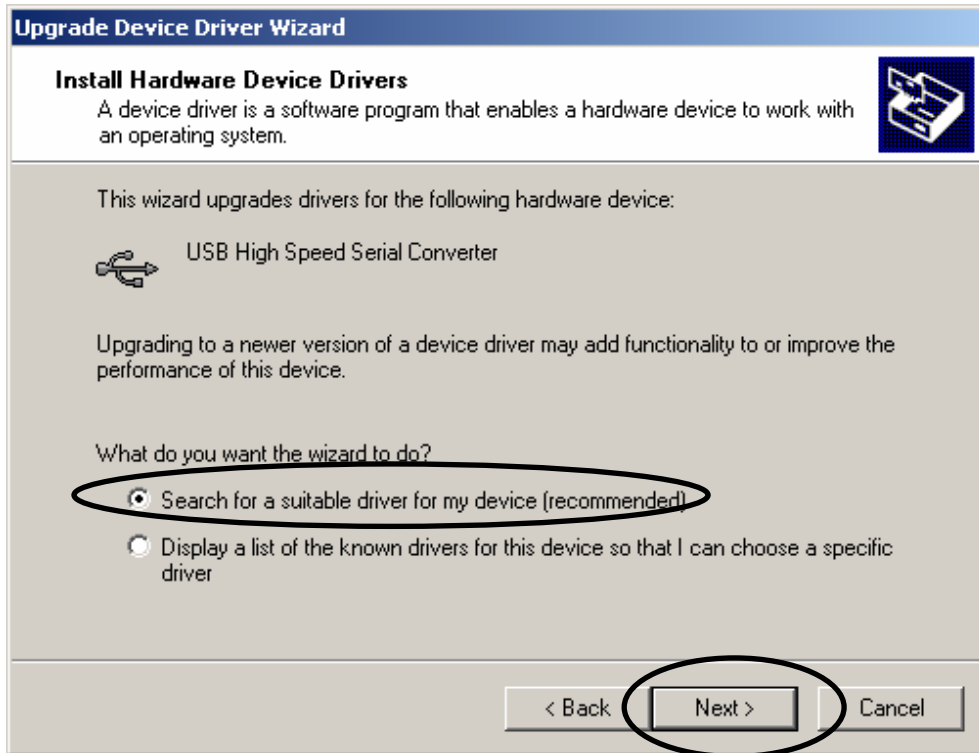

Step 3: Select optional search locations, if the "CD-ROM drivers" checkbox is selected, please insert the driver CD . Click "Next" to start and search.

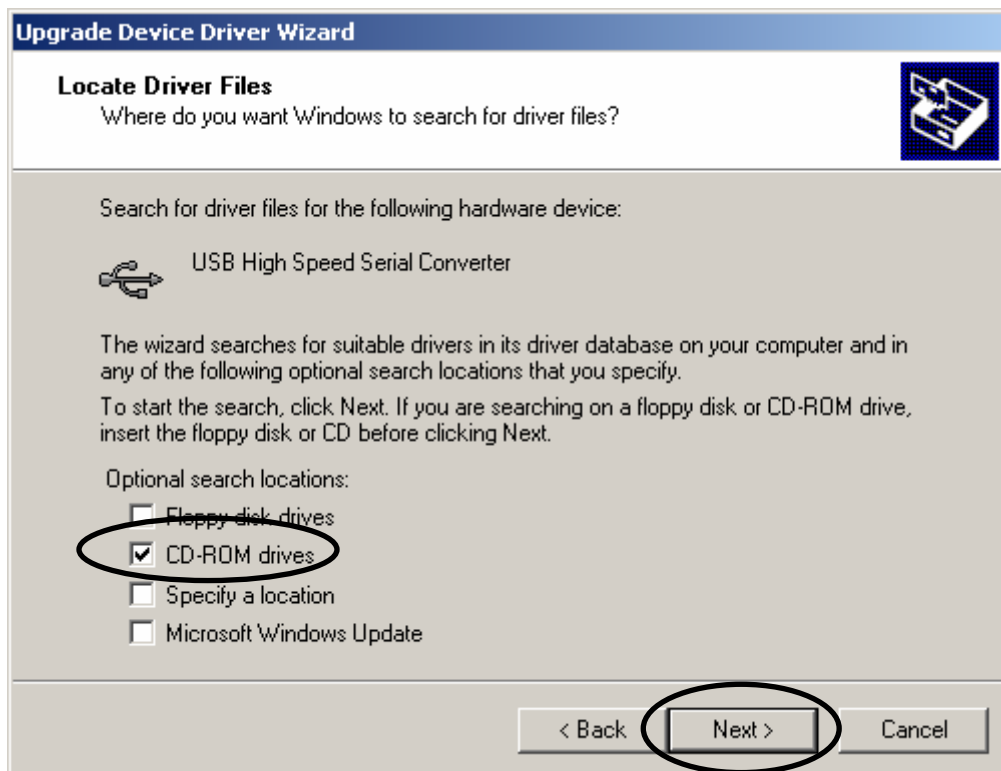

If the “Specify a location” is selected. Choose the correct path, H:\Napdos\7000\7561\Driver\ (The ‘H’ is the Disk that Package CD put in). Click “OK” to start and search.

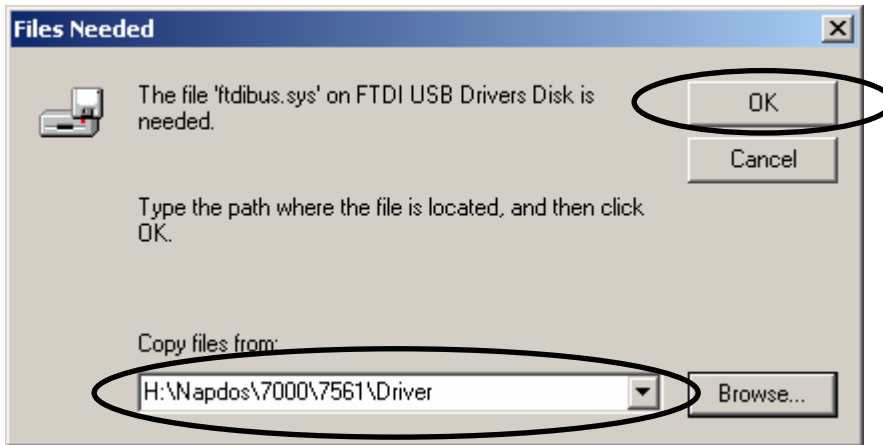

Step 4: Click the “Finish” button to complete installation of the device.



### 3.4.1.2 Install USB COM port

The installation method is the same as Sec3.4.1.1 “Install USB-RS232 driver”.

The Completion window is showed as below.



### 3.4.1.3 Find the serial number of the Com port

Step 1: Select the “Control Panel” from “Start” menu.

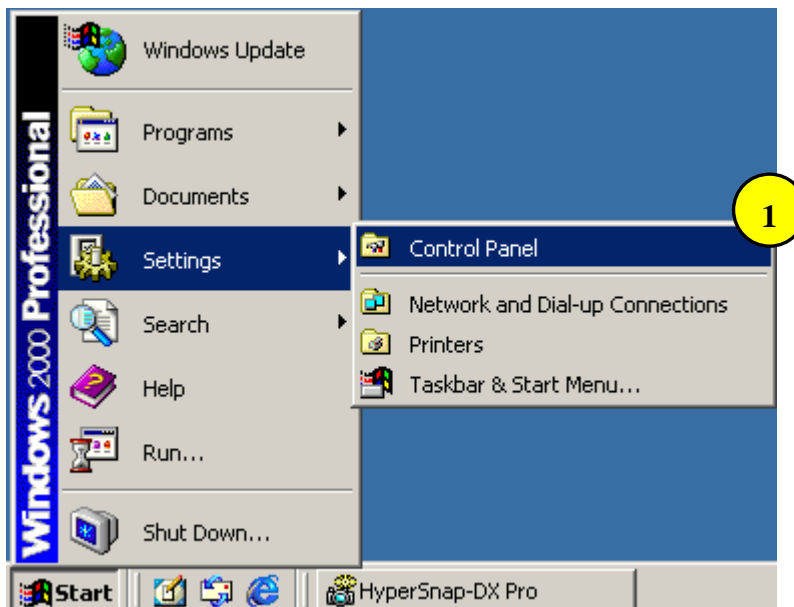

Step 2: Double Click “system” icon to open the “system properties” dialog box and Select the “Device Manager” button from this dialog box.

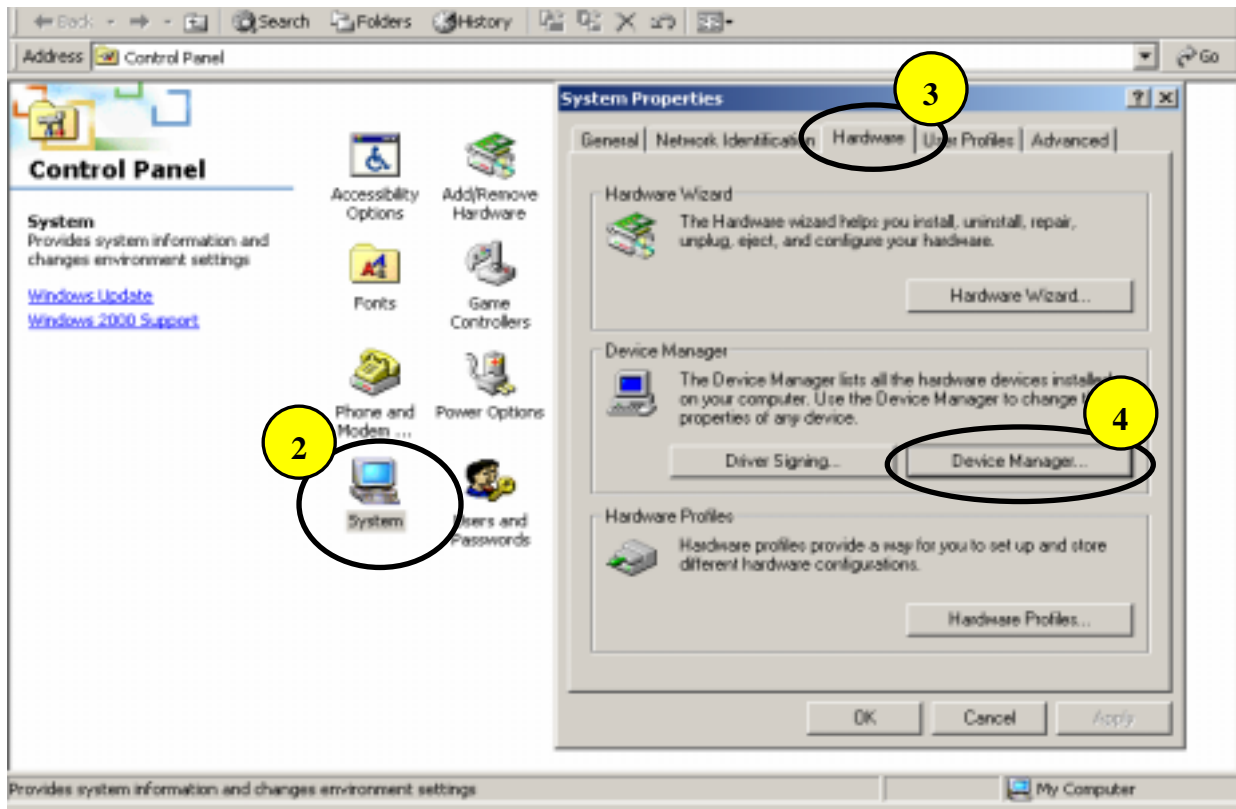

Step 3: Click the symbol ‘+’ to expand the tree view of Ports from the “Device Manager” window. Find the Serial number of your com port. (Find the USB serial port “COM3”)

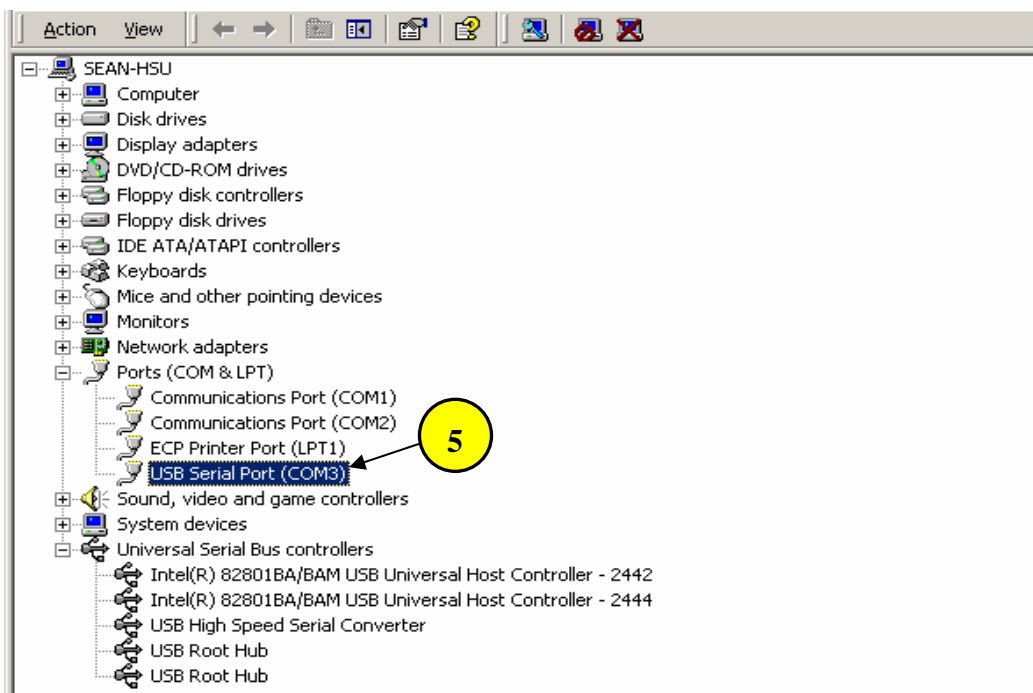

### 3.4.1.4 Uninstall drivers

Right-click the “USB High Speed Serial Converter” item, a menu is shown, select the “Uninstall” item to remove the USB-RS232 driver. Uninstalling the driver of the USB Com Port is the same as above.

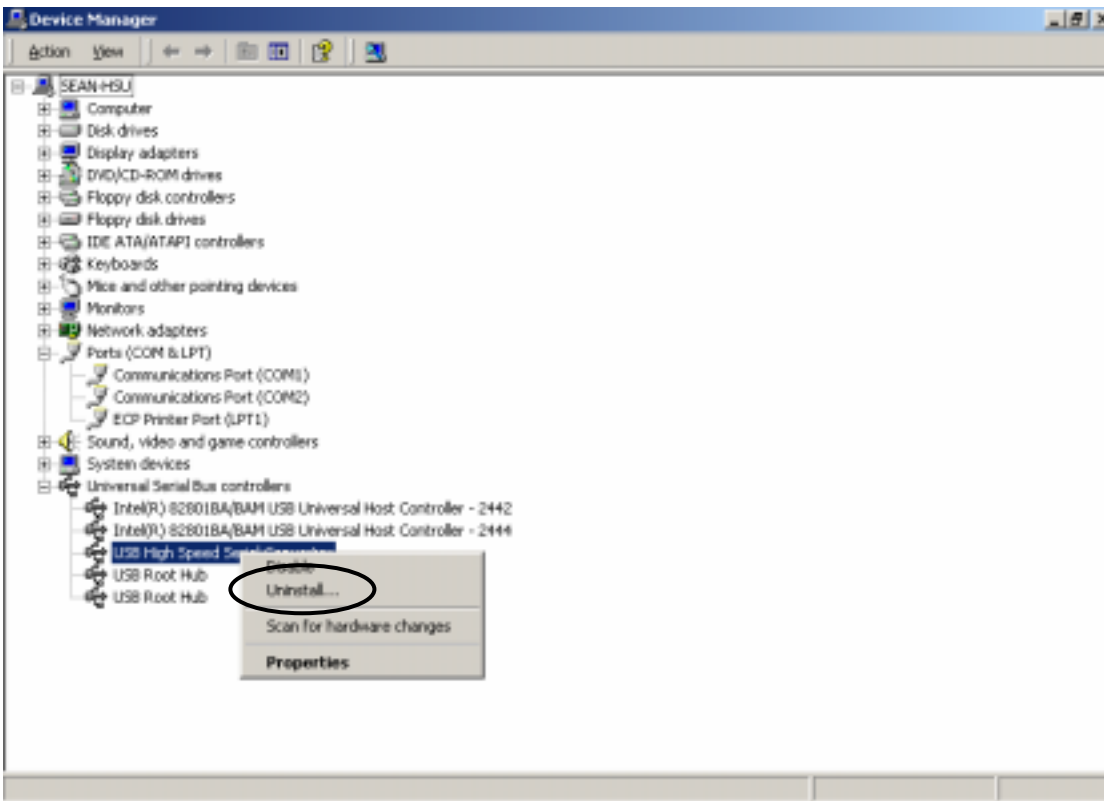

### 3.4.1.5 Changing the COM Port Number

From “Device Manager”, select ”View devices by type”, then “Ports (COM & LPT)”. Select the USB serial port and click ” Properties”. Select the “Port Settings” tab, then click Advanced. Choose the required COM port number from the list and click OK.

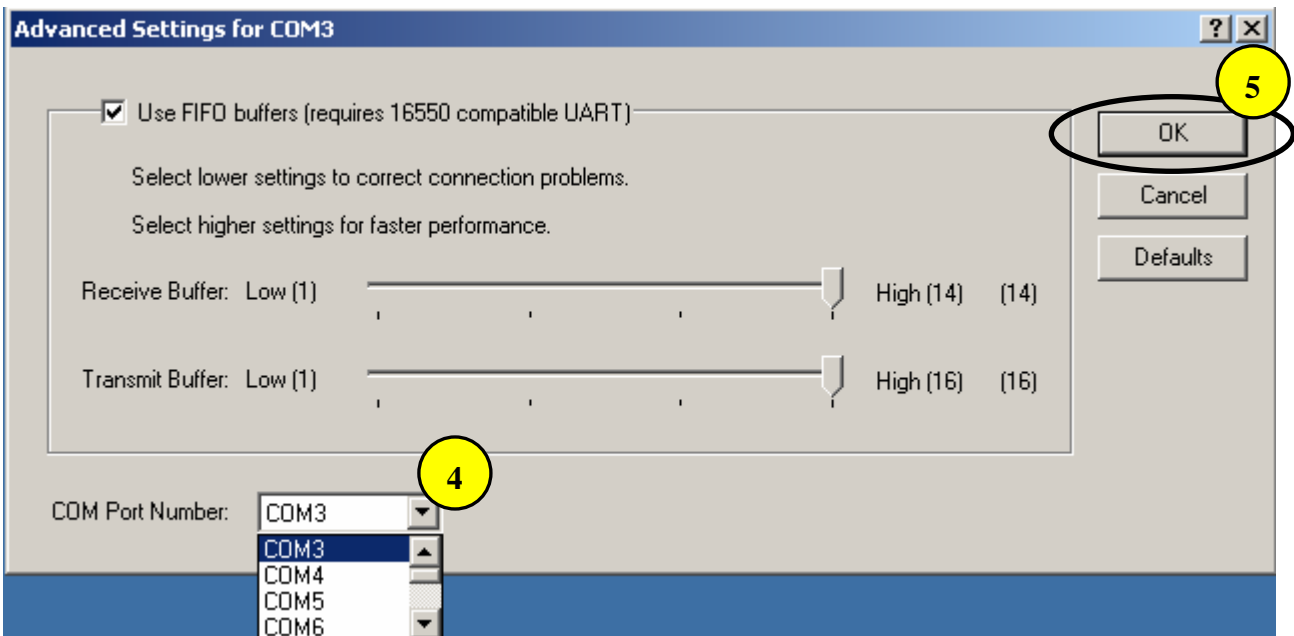
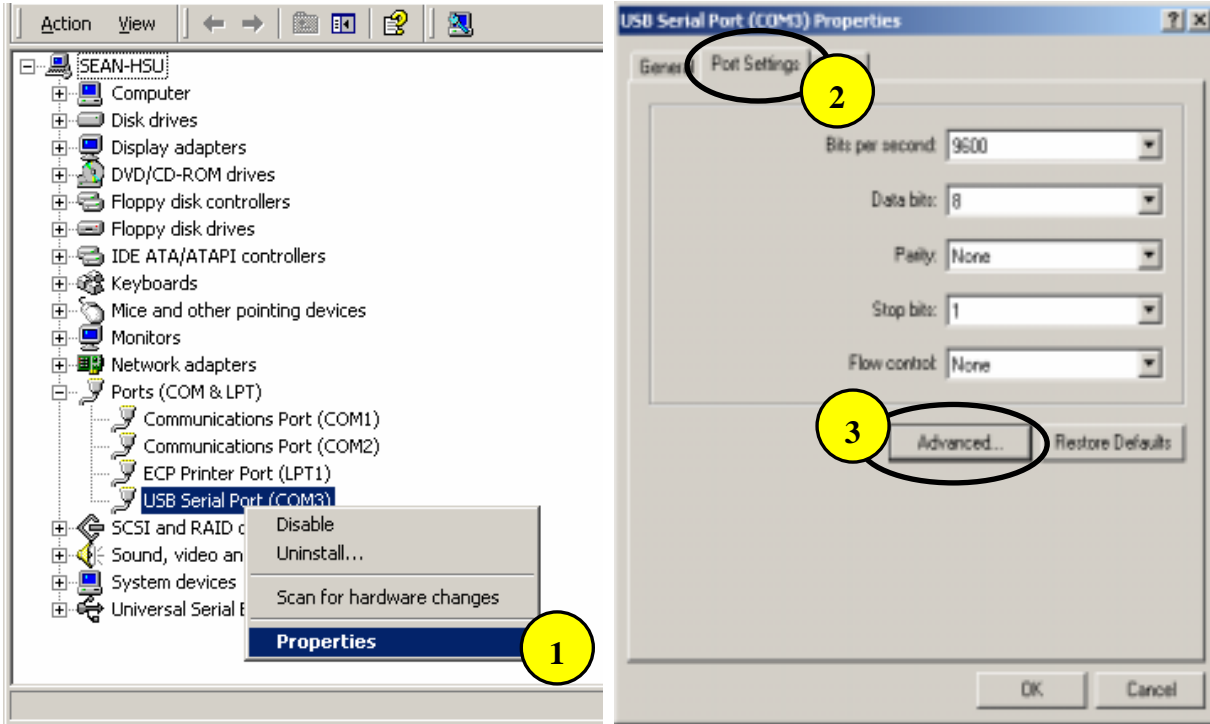

## 3.4.2 Installation under Win98/ME

### 3.4.2.1 Install USB-RS232 driver

Follow the steps below:

Step 1: Plug the USB cable into the USB HUB port located in the back of your computer (the “Add New Hardware Wizard” window is shown as below),Click “Next” to continue.



Step 2: Click “Next” to initiate a search for the best driver for your device.

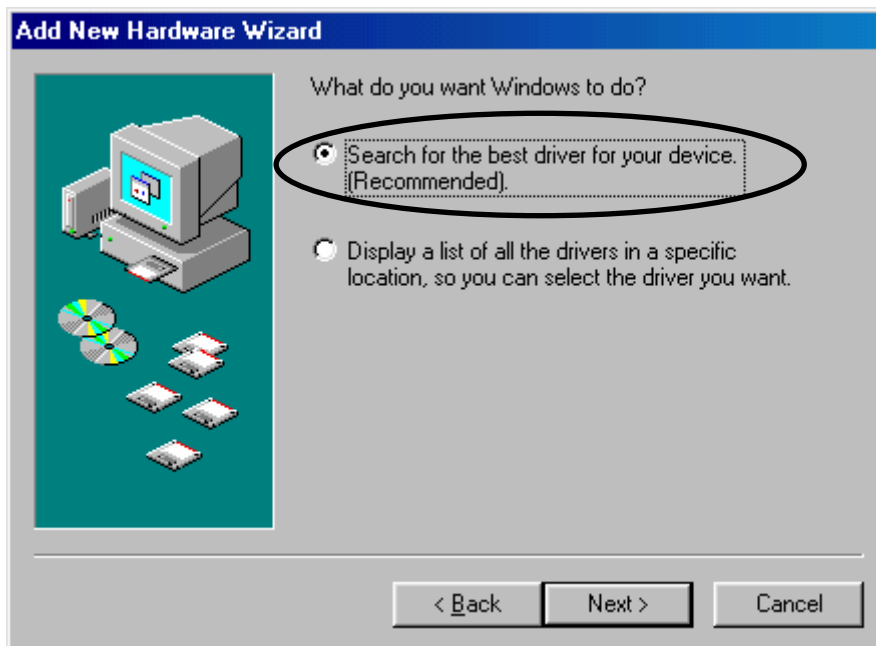

Step 3: Select optional search locations(like “CD-ROM drive”).  
Click “Next” to start and search.



Step 4: Click “Finish” to finish installing the device.



### 3.4.2.2 Install USB COM port

The installation method is the same as Sec3.4.2.1 “Install USB-RS232 driver”.

Please refer to Page 32.

### 3.4.2.3 Find the serial number of Com port

Step 1: Select the "Control Panel" from "Start" menu.

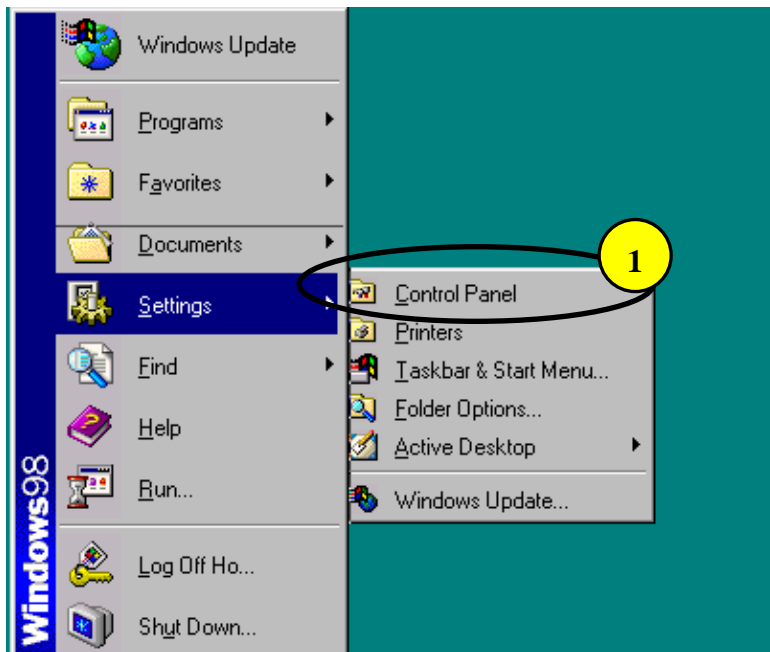

Step 2: Double Click the "system" icon to open the "system properties" dialog box, and Select the "Device Manager" from this dialog box.

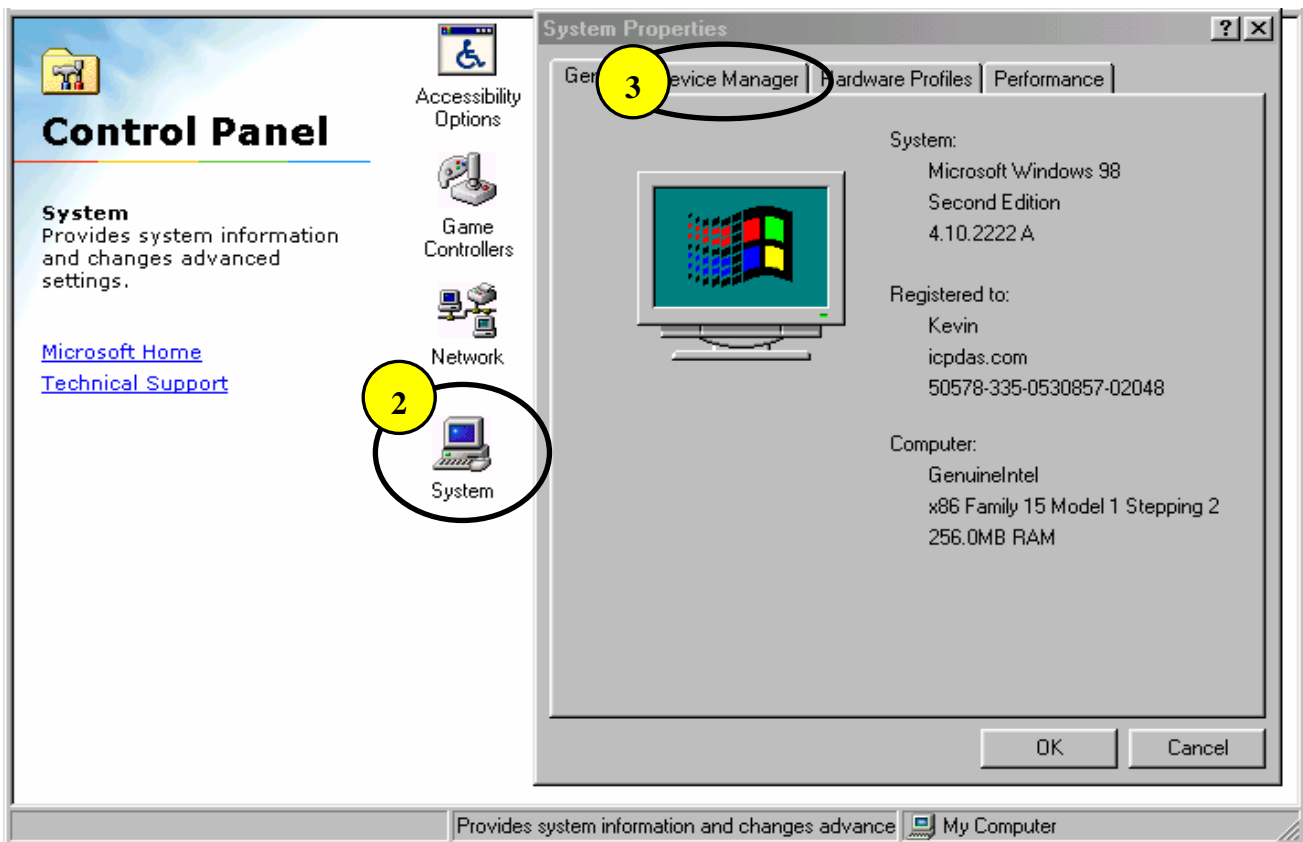

Step 3: Click the symbol '+' to expand the tree view of Ports from the "Device Manager" window. Find the Serial number of your com port.(Find the USB serial port "COM3")

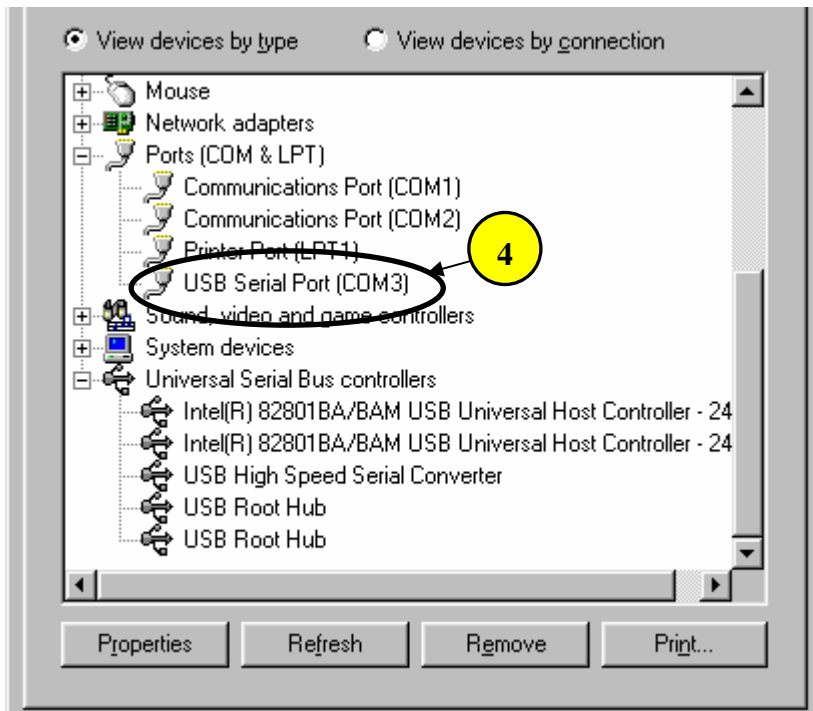

### 3.4.2.4 Uninstall drivers

Right-click the "USB Serial Port(COM3)" item,a menu is shown,select the "Remove" item to remove the USB-RS232 driver. Uninstalling the driver of the USB RS232 driver is the same as above.

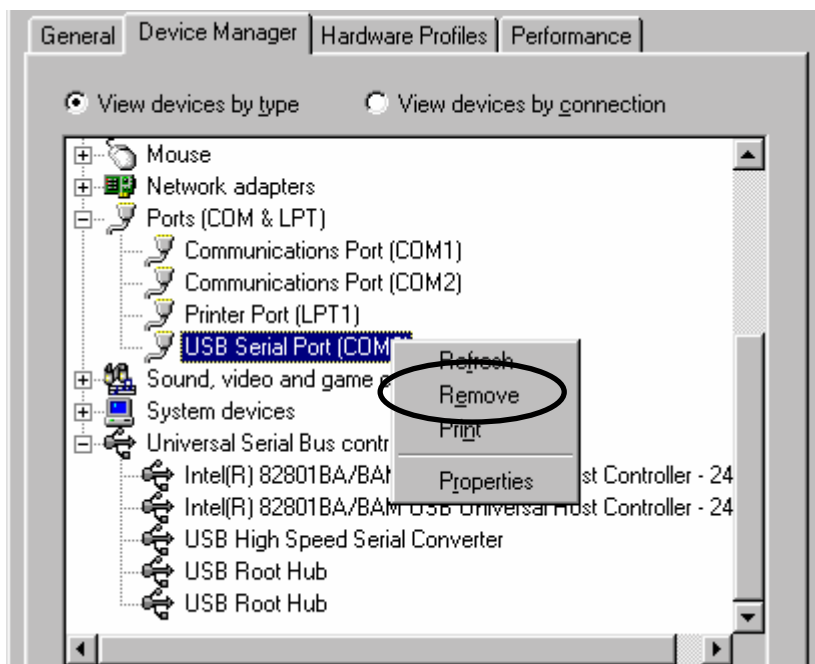

### 3.4.2.5 Changing the COM Port Number

Step 1: From “Device Manager”,select “View devices by type”, then “ Ports(COM & LPT)”.Select the USB serial port(COM3) and right-click to open ” Properties”.

Step 2: Select the “Port Settings” tab,then click Advanced.Choose the required COM port number from the list and click OK.

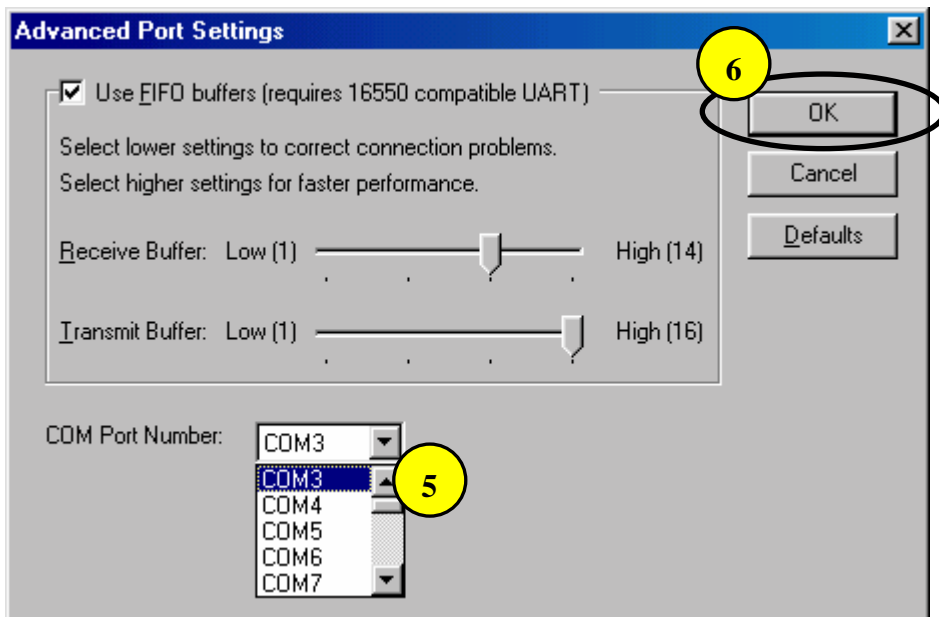
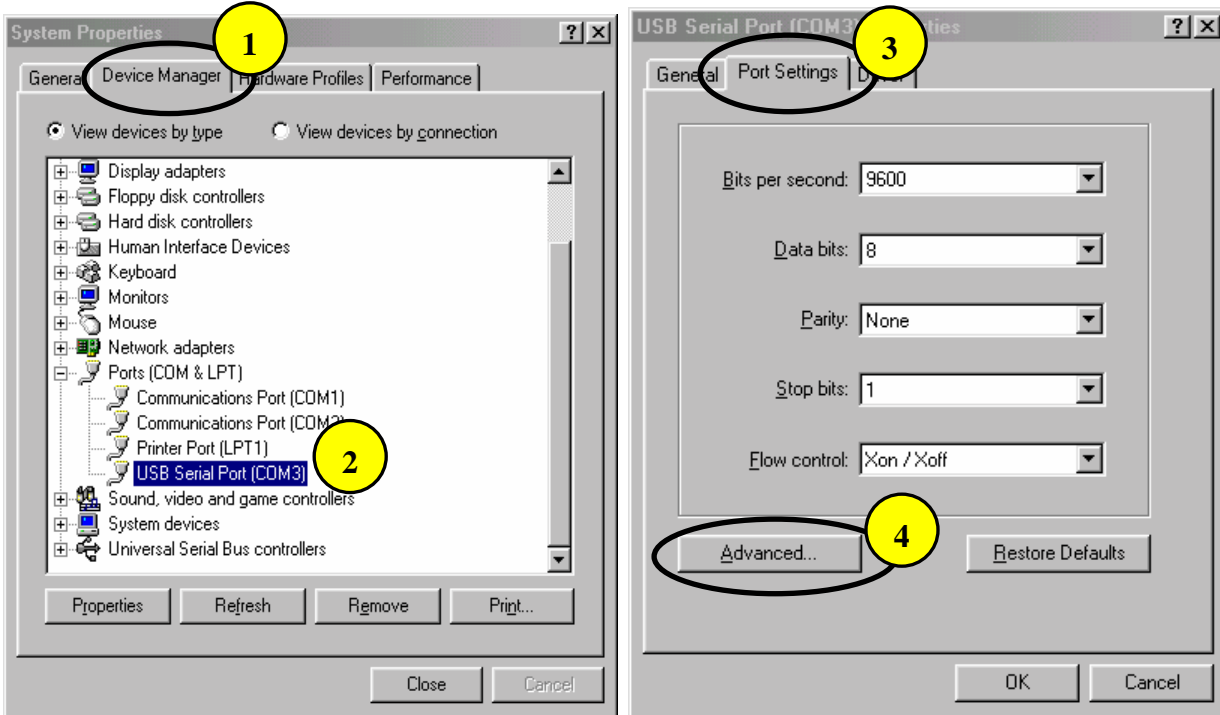

## 4. 7510/7510A

### 4.1 Pin Assignment and Specifications

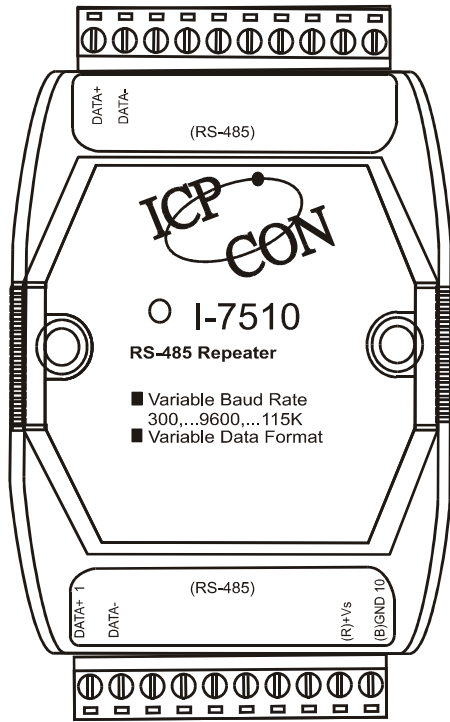

Fig 24

#### 7510 : RS-485 Repeater

- Input : two-wire RS-485, (D+,D-), protocol
- Output : two-wire RS-485, (D+,D-), protocol
- Speed : “Self Tuner” inside, auto switching baud rate, from 300 to 115200 BPS
- Isolation voltage : 3000V
- Connector : plug-in screw terminal block
- Power requirements : +10V to +30VDC
- Power consumption : 2.2W(Max)

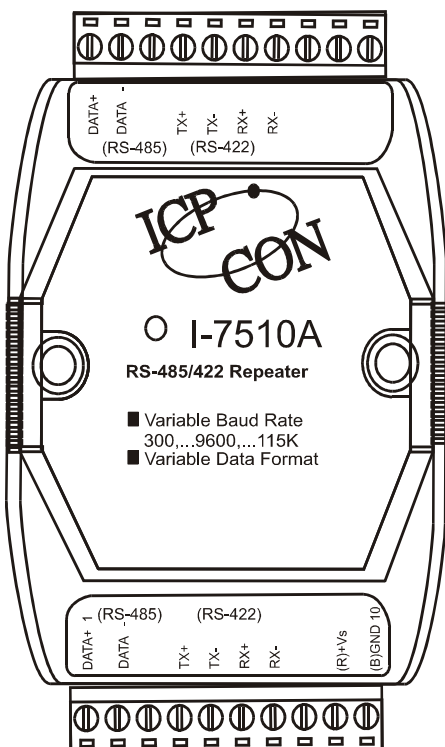
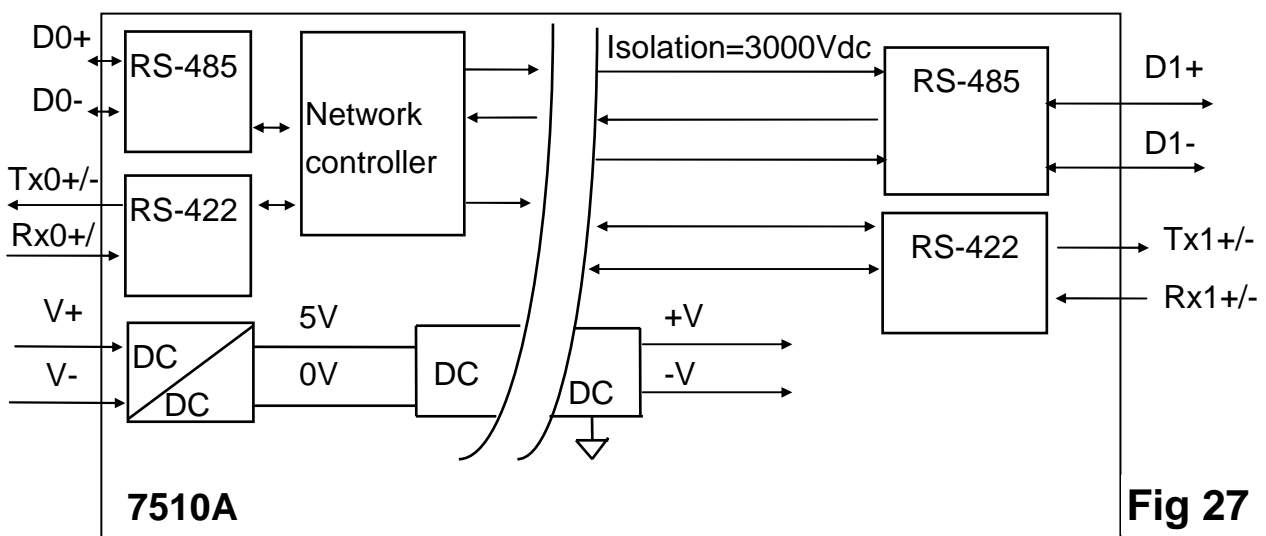
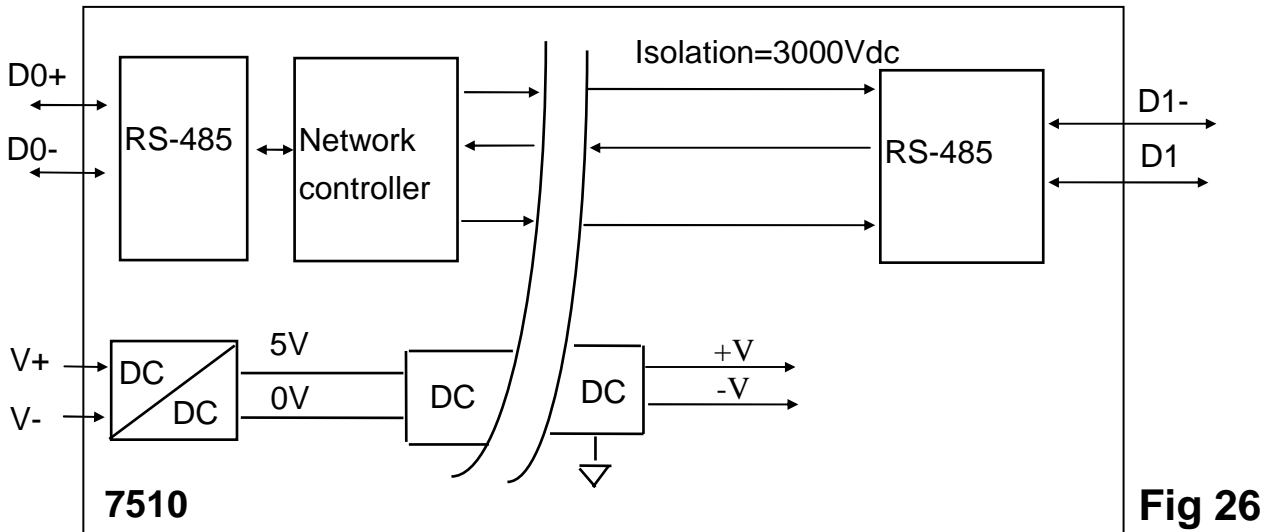

Fig 25

#### 7510A : RS-485/RS-422 Repeater

- Input : RS-485/RS-422
- Output : RS-485/RS-422
- Speed : “Self Tuner” inside, auto switching baud rate, from 300 to 115200 BPS
- Isolation voltage : 3000V
- Connector : plug-in screw terminal block
- Power requirements : +10V to +30VDC
- Power consumption : 2.2W(Max)

## 4.2 Block Diagram



## 4.3 Basic Wire Connections

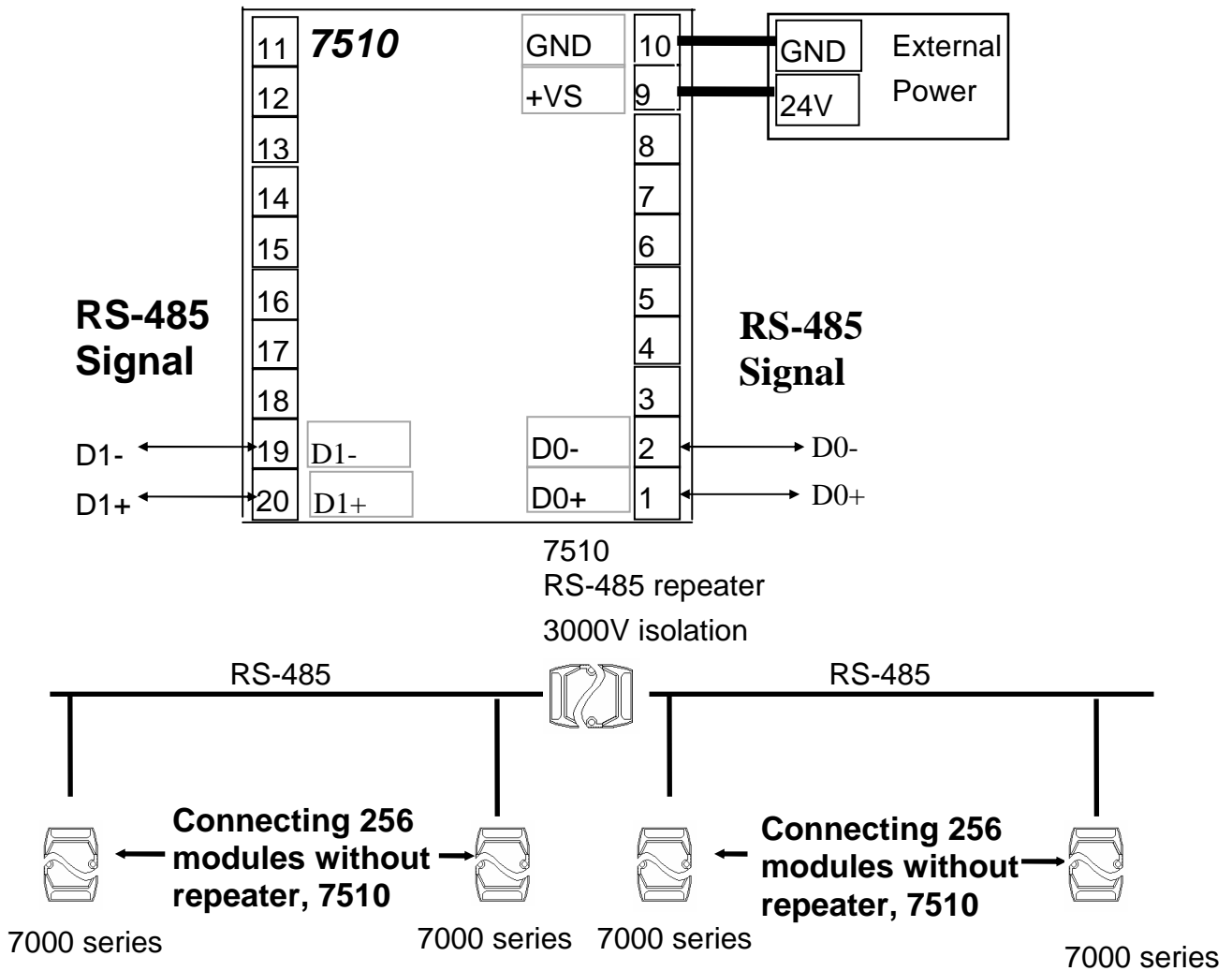

**Fig 28**

The three functions of the 7510 are given as follows : (refer to Sec. 2.6 for details)

- (1) **extends RS-485 network if the path is over 4000 ft or 1.2 Km**
- (2) **extends RS-485 network if connecting over 256 modules**
- (3) **cuts a long RS-485 path into several isolated short RS-485 paths for protection**

# 5. 7000 RS-485 Networking

## 5.1 Standard/Isolation Configuration

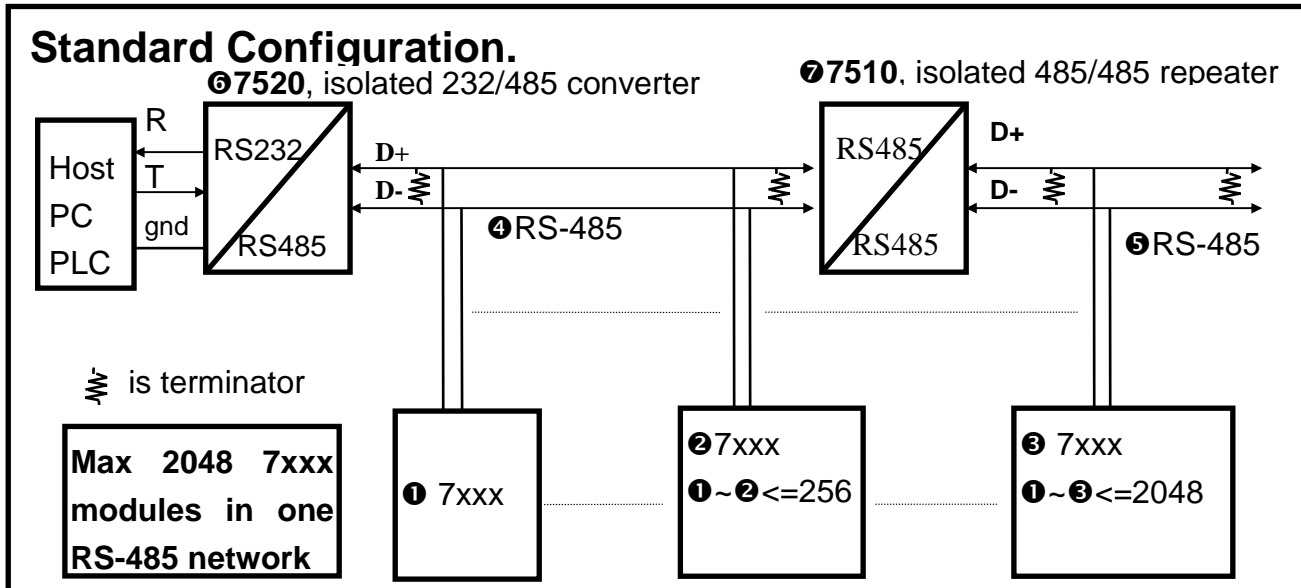

Fig 29

The Host PC/PLC will send out a command string from its RS-232 port. The ⑦7520 will convert these RS-232 signals into a RS-485 signal and isolate the host from ④RS-485 network.

The 7000 series modules, including D/I, D/O, A/D, D/A, Timer/Counter and MMI modules, will be directly connected to ④RS-485. These 7000 series modules can connect a max. of 256 modules to the ④RS-485 network without a repeater, the 7510. That is to say, there can be 256 modules from ①7xxx to ②7xxx. If there are over 256 modules, the repeater 7510 must be added to extend the ④RS-485 to ⑤RS-485. Then there can be another 256 modules connected to the ⑤RS-485 network. **This is the first function of the 7510.**

The module address can be changed from 00 to FF a total of 256 max., therefore there are a max. of 256 modules in one RS-485 network if all the modules communicate with the same speed.

- (1) Because the 7000 can communicate with different baud rates in the same RS-485 network, the ①7xxx, ②7xxx and ③7xxx can be communicated to HOST PC/PLC with a different baud rate.
- (2) The 7000 series can be programmed to 1200, 2400, 4800,

9600, 19200, 38400, 57600, 115200, a total of 8 different speed.

(3) The 7000 modules can share the same module address if their baud rate are different. For example,

①7xxx=module address 01, baud rate=1200

②7xxx=module address 01, baud rate=9600

③7xxx=module address 01. Baud rate=115200

These three modules can share the same RS-485 network, generated by ⑥7520.

(4) Therefore there are 256\*8=2048 modules max. in one RS-485 network with a repeater(7510).

The “search function” given in NAP7000S can search for all these 2048 modules in one RS-485 network. Refer to “NAP7000S User Manual” for completely source listing of “search function”.

When the RS-485 network is over 4000 ft or 1.2Km, the RS-485 repeater(7510) must be added to extend the RS-485 network. For example, if the ④RS-485 is over 4000 ft or 1.2 Km, the ⑦7510 must be added to extend ④RS-485 to ⑤RS-485. And if the ⑤RS-485 is too long, the user should use another 7510 to extend another RS-485 network. **This is the second function of 7510.**

The power ground of the 7000 series is common ground to the RS-485 network. This feature is the same as the Adam 4000, Nudam 6000 and DATAFORTH 9B series. Therefor all the modules in the same RS-485 network are common ground. For example, the all modules between ①7xxx and ②7xxx share the same ④RS-485 network and all are common ground. The ④RS-485 length can be up to 4000 ft or 1.2 km, this is a very long path. This long path makes the RS-485 network very susceptible to network noise by high energy transient in this environment. If this noise is too great, all the modules in the RS-485 network may be damaged simultaneously. This is highly possible and occurs often in real world applications. It is strongly recommended to add another isolation repeater, the 7510, to break the long path RS-485 network into several short RS-485 networks to avoid all the modules being damaged at the same time. **This is the third function of 7510.**

For example, the ④7510, ⑤7510, ⑥7510 in Fig 22 are used to isolate local modules from ①RS-485 network. If there is high energy transient on ①RS-485 network, all the local modules will be safe. Therefore we strongly recommend the user to select isolated connections, refer to Fig 24.

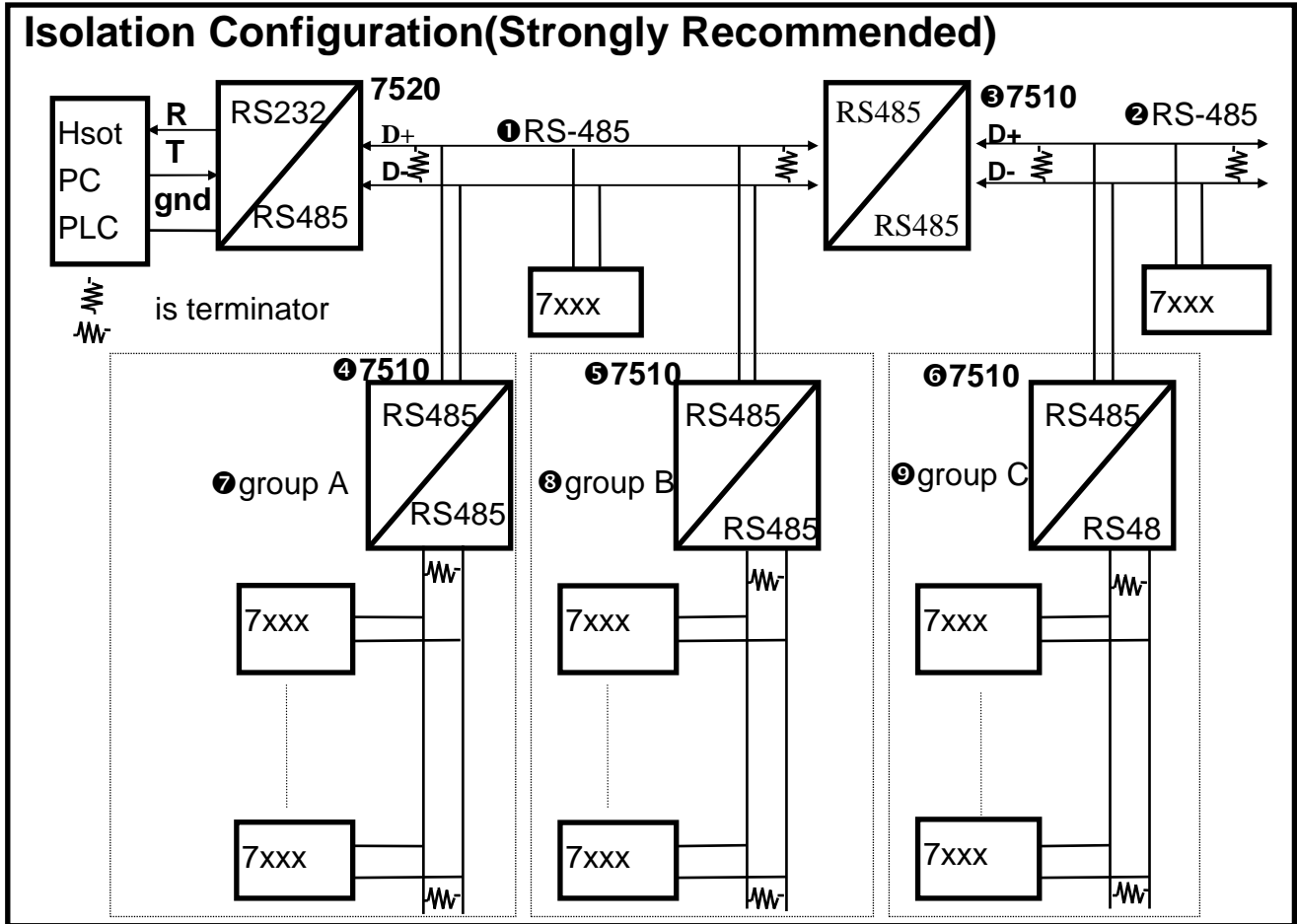

**Fig 30**

If the RS-485 network is not over 100 meters, the terminated resistors are not needed. However, it may be necessary to insert two terminated resistors at both end of the RS-485 segment. It is not easy to calculate the value of a terminator resistor. The best way to do this is to use an oscilloscope to check the RS-485 signal directly. If the impedance match of RS-485 network is OK, the oscilloscope will show a very nice square wave. If these square wave signals are distorted, the user will need to insert two terminators at both end of the RS-485 segment.

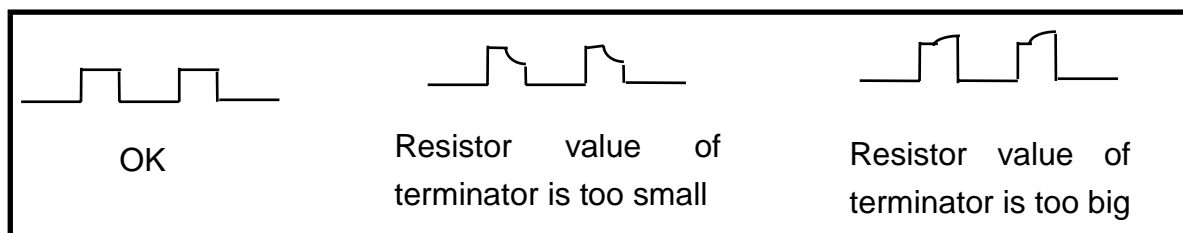

**Fig 31**

It is recommended to use the “trial and error” rule. The trial and error rules are given as follows:

- (1) If the length of RS-485 is about 1.2 Km, try 110 $\Omega$  first  
If the length of RS-485 is about 600 m, try 220 $\Omega$  first  
If the length of RS-485 is about 300 m, try 330 $\Omega$  first
- (2) Run TEST.EXE of NAP7000S  
Select function\_5, run continuously for at least 8 hours to make sure communication is OK.
- (3) If function\_5 finds many communication errors, use an oscilloscope to check the wave form. The wave form will tell you whether the terminator is too small or too big. Then adjust your terminator and run TEST.EXE again.
- (4) If the correct terminators are found, run the TEST.EXE continuously for at least 8 hours to make sure there are no communication errors.

The function\_5 of TEST.EXE, given in NAP7000S, will automatically read “testing command” from TEST.DAT and continuously perform “send-receive-testing”. It will continuously test and record all testing results. Therefore this function is especially designed for RS-485 network stability evaluation. If you run this function\_5 continuously for 8 hours and find no check errors, this means that your RS-485 network is very stable. Also this means that your terminators match well now.

**NOTE 1 :** The value of the terminator depends on the RS-485 wire used. If the RS-485 path is very long, don't use a cheaper wire. It is recommended to select a high quality wire such as the Belden 1583A.

**NOTE 2 :** The terminator is different for various applications. Therefore we can not provide a terminator with the 7520 or the 7510. The user must choose the correct terminator by themself. It is recommended to use a carbon, 1/4w resistor.

## 5.2 PLC Networking Applications

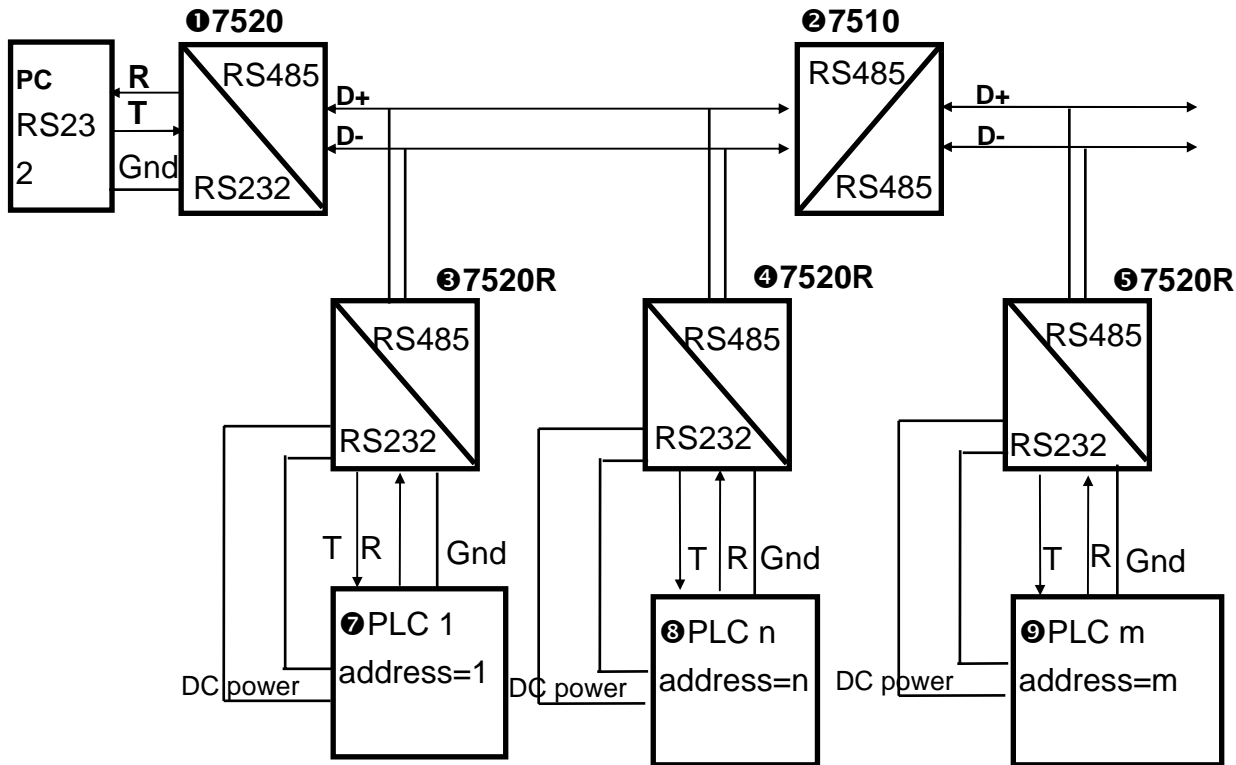

Fig 32

These PLCs can be used at **different baud rates & different configurations**. For example,

PLC-1=1 start + 7 data + 1 stop=9-bit/byte, baud rate=1200

PLC-n=1 start + 8 data + 1 parity + 1 stop=11-bit/byte, baud rate=9600

PLC-m=1 start + 8 data + 1 parity + 2 stop=12-bit/byte, baud rate=115200

OMRON CQM1 = 1 start + 7 data + 1 even parity + 2 stop = 11-bit/byte  
 OMRON C200 = 1 start + 7 data + 1 even parity + 2 stop = 11-bit/byte

The ①7520 can be the 7520 or 7520R, refer to Sec. 2.5 for details.

The ③7520R, ④7520R, ⑤7520R can be the 7520 or 7520R, refer to Sec. 2.5 for details. In this configuration, the ⑦PLC1, ⑧PLCn, ⑨PLCm provides DC power to ③7520R, ④7520R, ⑤7520R. This is the cheapest to the 3000V high isolation. The user should not replace the 7520R, ③, ④, ⑤, with the 7520.

Refer to “NAP7000S User Manual” for PLC networking software details.

## 5.3 PC Networking Applications

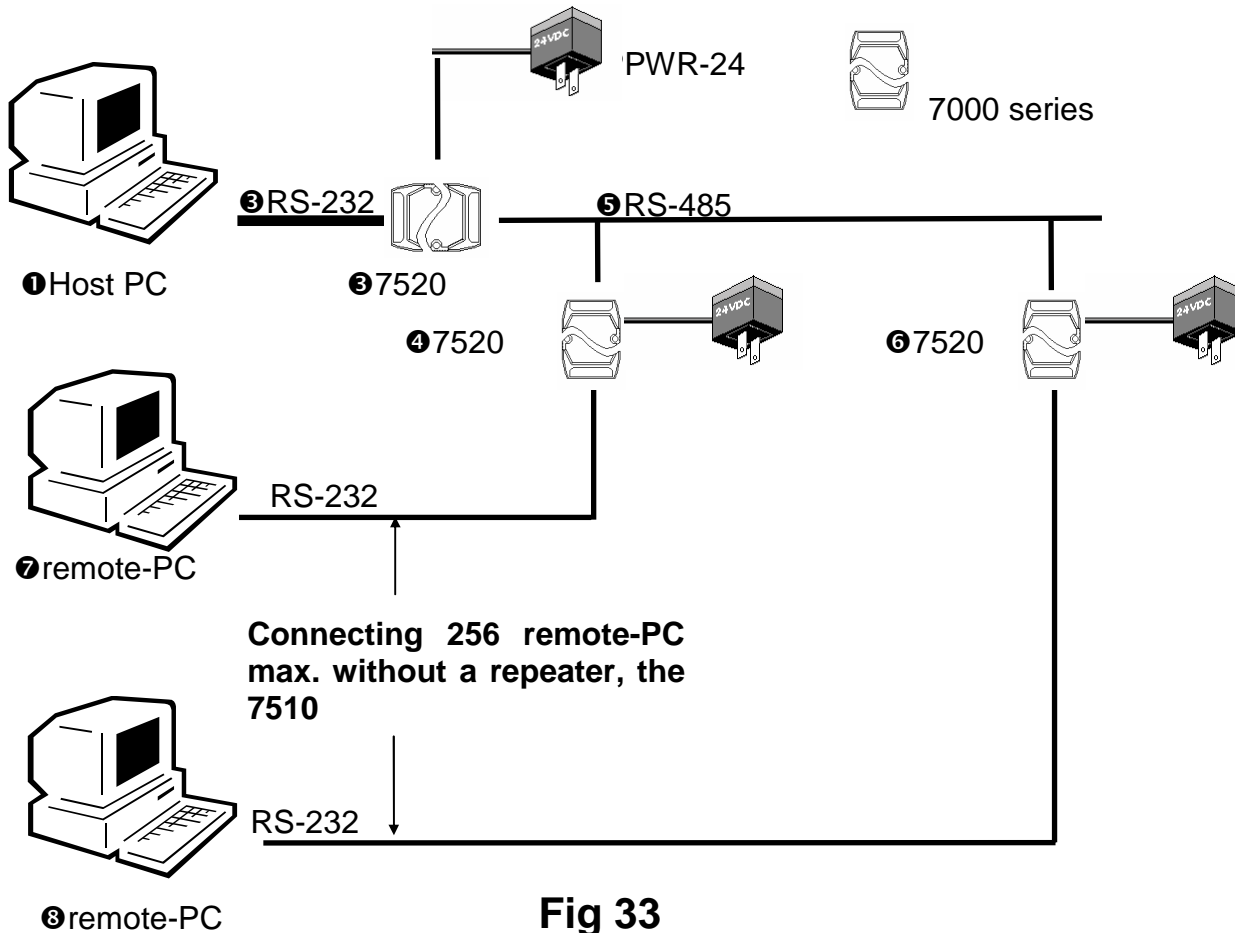

**Fig 33**

Every remote-PC must have a unique address. This unique address is similar to the module address of the 7000 series. We call it a “slave-PC address”. The module address of the 7000 series is limited to 256, but the slave-PC address is unlimited. The user can connect thousands of PCs in one RS-485 network by using a repeater, the 7510.

Refer to “NAP7000S User Manual” for software details. Using this software, the host-PC can send out commands to remote-PCs, just like sending commands to the 7000 series modules. The remote-PC will receive these commands and execute the command if the destination address matches it’s local address.

This remote-PC and 7000 series modules can use the same RS-485 network. The host-PC can send out the 7000 series commands and send out PC-networking commands at different times. The modules and remote-PCs will receive their command respectively. This makes the network very low cost, with high flexibility and reliability. This unique feature is not found elsewhere in the world.

## 5.4 RS-232 Devices Network

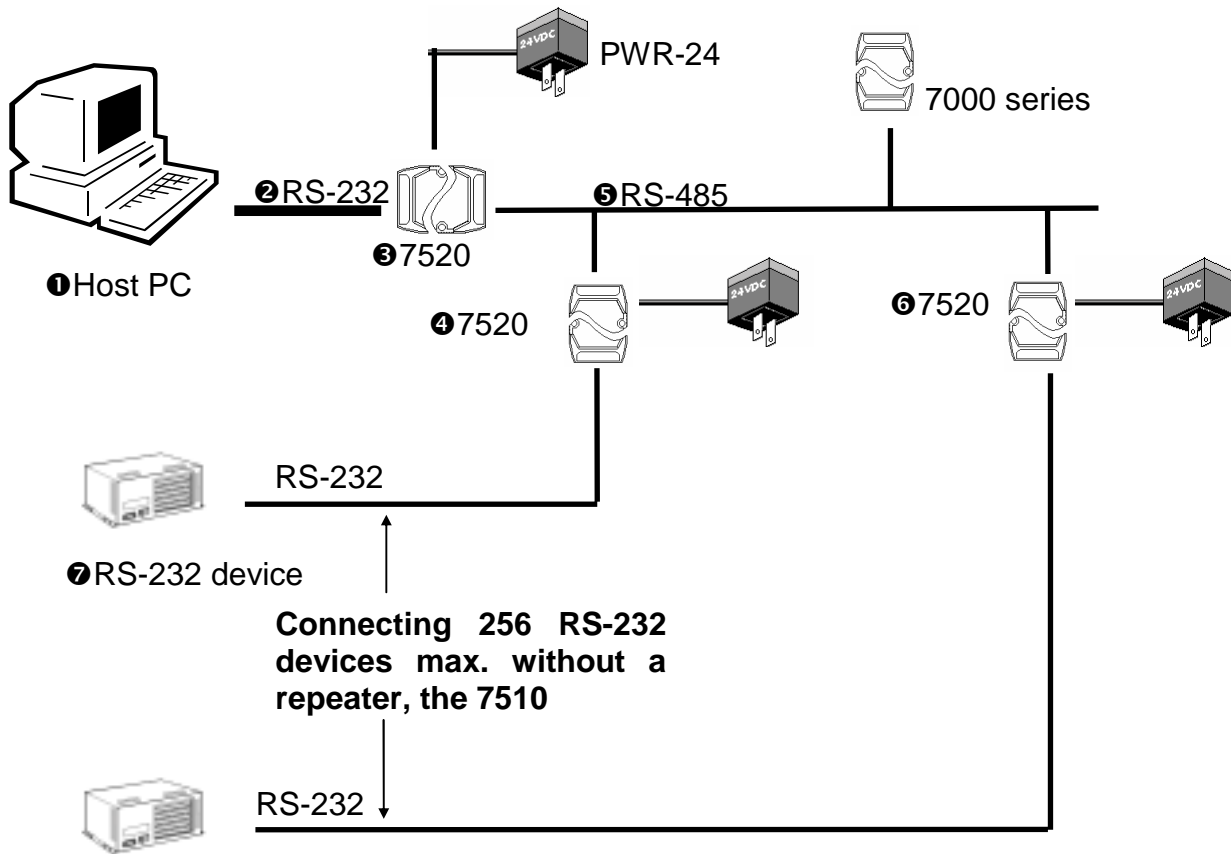

**Fig 34**

Some RS-232 devices can be connected to the 7000 RS-485 network very easily, just like the PC or PLC introduced in Sec 2.7 and Sec. 2.8. These RS-232 devices must adhere to 3 rules given as follows :

**Rule 1 : cannot send out the RS-232 signal in normal, operating state.**

**Rule 2 : every device has a unique device address**

**Rule 3: will not send out a RS-232 signal if the destination address does not match with the device address**

The software for RS-232 device networking and PLC networking is very similar. The only difference is the command format. The command format of PLC is always different for different manufacturers. Refer to “NAP000S User Manual” for software details.

# 6. Quick Starting the 7000 Series

## 6.1 Find Status of Unknown Module

Wire connection : refer to Sec. 2.4

Test program : refer to "NAP7000S User Manual" for TEST.EXE

Connect **INIT\*\_pin** to **GND\_pin** first as follows.

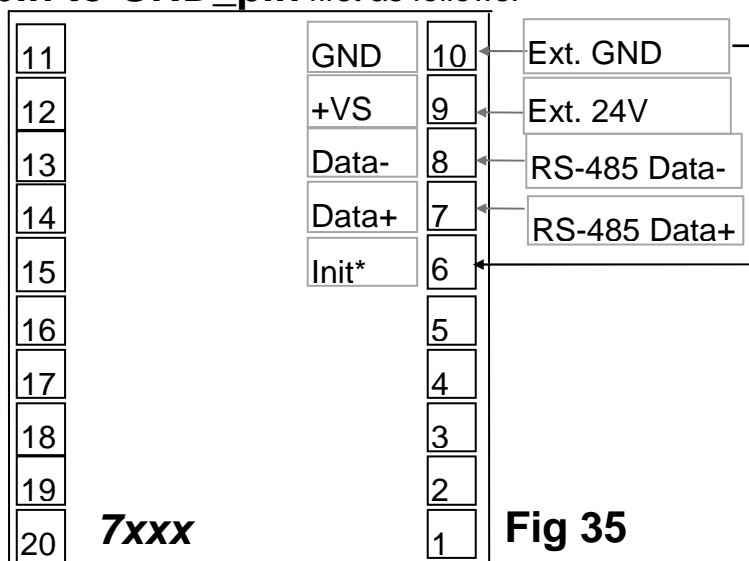

Fig 35

The steps to finding the status of an unknown module are given as follows.

1. Wire connection, **INIT\*\_pin=GND**, power on and run **test.exe**
2. press **2**
3. press **\$002[Enter]** → Receive=!02080A40
4. press **2**
5. press **%0001080600[Enter]** → Receive=!01
6. power off, disconnect **INIT\*\_pin** (pin 6) and **GND\_pin** (pin\_10) and power on
7. press **2**
8. press **\$012[Enter]** → Receive=!01080600
9. press **2**
10. press **\$01M[Enter]** → Receive=!017017
11. press **2**
12. press **\$01F[Enter]** → Receive=!01A1.3

**NOTE:**If the **INIT\*-pin** is connected to **GND-pin**, the **7xxx** will go to its default setting as follows:  
(1) module address=00  
(2) baud rate=9600  
(3) checksum is disable

- step 3 : read the module status with the INIT\*\_pin connected to the GND\_pin and find that module address=02, baud rate=115200, checksum is enable.
- step 5 : change this module to address=01, baud rate=9600, checksum disable
- step 6-12 : disconnect the INIT\*\_pin and read back the module status

---

## 6.2 Changing Module Address

Wire connection : refer to Sec. 2.4

Test program : refer to "NAP7000S User Manual" for TEST.EXE

The steps to change module address are given as follows.

1. Wire connection, power on and run **test.exe**
  2. press **2**
  3. press **\$012[Enter]** → Receive=!01080600
  4. press **2**
  5. press **%0102080600[Enter]**→ Receive=!02
  6. press **2**
  7. press **\$022[Enter]** → Receive=!02080600
  8. press **2**
  9. press **\$02M[Enter]** → Receive=!027017
  10. press **2**
  11. press **\$02F[Enter]** → Receive=!02A1.3
- step 3: read the module status and find that module address=01, baud rate= 9600, checksum is enable.
  - step 5: change the module address from 01 to 02, the module address can be changed immediately, no need to power-off then power-on
  - step 7: read the module status based on the module address=02
  - step 9: read the module name
  - step 11 : read the firmware number of this module
  -

NOTE : If the user uses \$AA2 command to change module configuration, the new configuration code will be stored into EEPROM immediately. The configuration code includes module address, module type, baud rate code, checksum enable/disable code, calibration code, power-on value and safe value. The EEPROM data of the 7000 series can be read an infinite number or times and can be written about 100,000 times max. Therefore the user should not change the configuration code often when testing.

---

## 6.3 Changing Baud Rate

Wire connection : refer to Sec. 2.4  
Test program : refer to “NAP7000S User Manual” for TEST.EXE

The steps to change the baud rate of communication are given as follows.

1. Wire connection, power on and run **test.exe**
2. press **2**
3. press **\$012[Enter]** → Receive=!01080600
4. press **2**
5. press **%0101080A00[Enter]**→ Receive=?01
6. connect INIT\*\_pin (pin 6) to GND\_pin (pin\_10)
7. press **2**
8. press **%0101080A00[Enter]**→ Receive=!01
9. press **2**
10. press **\$012[Enter]**→ Receive=!01080A00
11. power off, disconnect INIT\*\_pin and GND\_pin, power on and run **test.exe**
12. press **0**
13. press **1[Enter]**(1/2/3/4 for COM 1/2/3/4)
14. press **115200[Enter]**
15. press **0[Enter]**
16. press **2**
17. press **\$012[Enter]** → Receive=!01080A00

- step 3 : read the module status, baud rate=9600
- step 5 : change baud rate with the INIT\*\_pin floating and the function will fail failure. If the user want to change the baud rate of the 7000 module, the INIT\*\_pin must be connected to the GND\_pin. If the INIT\*\_pin is left floating (unconnected), the 7000 module will echo ?AA to the user.
- step 8 : change baud rate to 115200 with the INIT\*\_pin connected to the GND\_pin. After this command, the baud rate will remain at 9600. The baud rate of the 7000 series will be changed only during the power-on period.

**NOTE:**

- (1) To change the baud rate, the INIT\*-pin must be connected to GND-pin
- (2) The baud rate will be saved into EEPROM immediately.
- (3) The module will change its baud rate only during the first power-on time.

- step 10 : read the module status, baud rate= 115200(this value, is stored in the EEPROM only). The baud rate is changed in step 8 but the baud rate of this module is still at 9600 BPS. When the module has powered-off-and-powered-on, the baud rate will be changed to 115200.
- step 11 : power off, then power on. The module will change its baud rate based on the EEPROM value only when the module has first powered-on
- step 13-16 : change TEST.EXE to baud rate 115200
- step 17 : use baud rate 115200 to read back the module status and find that the module is now communicating at baud rate 115200.

---

## 6.4 Checksum Enable/Disable

Wire connection : refer to Sec. 2.4

Test program : refer to "NAP7000S User Manual" for TEST.EXE

The steps to enable/disable checksum status are given as following.

1. Wire connection, power on and run **test.exe**
2. press **2**
3. press **\$012[Enter]** → Receive=!01080600
4. press **2**
5. press **%0101080640[Enter]**→ Receive=?01
6. connect the INIT\*\_pin (pin 6) to the GND\_pin (pin\_10)
7. press **2**
8. press **%0101080640[Enter]**→ Receive=!01
9. press **2**
10. press **\$012[Enter]** → Receive=!01080640
11. power off, disconnect the INIT\*\_pin and the GND\_pin
12. power on and run test.exe, then press **0**
13. press **1[Enter]**(1/2/3/4 for COM 1/2/3/4)
14. press **9600[Enter]**
15. press **1[Enter]**
16. press **2**
17. press **\$012[Enter]** → Receive=!01080640**B1**

### **NOTE:**

- (1) To enable the checksum, the INIT\*-pin must be connected to the GND-pin
- (2) The checksum status will be saved into the EEPROM immediately.
- (3) The module will change its checksum state only during the first power-on time
- (4) The TEST.EXE will send out the extra checksum byte if checksum is enabled.
- (5) The 7000 will echo the extra checksum byte. The extra checksum byte is "B1" in this example.

- step 3 : read the module status, chksum=DISABLE
- step 5 : enable checksum with the INIT\*\_pin floating, so the function fails. If the user want to enable the checksum bytes of the 7000 module, the INIT\*\_pin must be connected to the GND\_pin. If the INIT\*\_pin is left floating (unconnected), the 7000 module will echo **?AA** to the user.
- step 8 : enable checksum with the INIT\*\_pin connected to the GND\_pin. After this command, the checksum is still in the DISABLE state. The state of checksum will be changed only during the power-on period. But the checksum status is saved into EEPROM immediately.
- step 10 : read the module status from EEPROM and find that checksum is in the ENABLE state. The state of checksum was changed in step 8 but this module is still in checksum DISABLE state. Only when the module has powered-off-and-powered-on, the state of checksum will be changed to ENABLE
- step 11 : power off, disconnect the INIT\*\_pin and the GND\_pin. Power on. The checksum status of this module is enabled now.
- step 12-17 : change TEST.EXE to baud rate 9600 and checksum enable, then read back the module status and find that the module is in checksum enable state now.

The steps to compute checksum are given as follows:

1. step 1: checksum=0;
2. step 2: for all command byte checksum = checksum + command byte
3. step 3: checksum=checksum&0xff
4. step 4 : convert checksum to ASCII high byte and ASCII low byte

for example, command = **\$012[Enter]**  
checksum = **\$+0+1+2=0x24+0x30+0x31+0x32=0xB7**  
checksum & 0xff = 0xB7  
checksum ASCII high byte = ASCII B = 0x42  
checksum ASCII low byte = ASCII 7 = 0x37  
command with checksum = **\$012B7[Enter]**

---

## 6.5 QBASIC Demo Program

It is very easy to use QB to send out an RS-232 command. The program listing is given as follows:

```
10 OPEN "COM1:9600,N,8,1,RS,CS,CD,DS" AS #1
20 CMD$="$012"
30 PRINT #1, CMD$
40 RESULT$=INPUT$(9,#1)
50 PRINT "Send=$012 --> Receive=",RESULT$
60 CLOSE:END
```